

(19)



(11)

EP 4 114 252 B1

(12)

EUROPEAN PATENT SPECIFICATION

(45) Date of publication and mention of the grant of the patent:
28.01.2026 Bulletin 2026/05

(21) Application number: **21763774.3**

(22) Date of filing: **05.03.2021**

(51) International Patent Classification (IPC):

A61B 5/00 <small>(2006.01)</small>	A44C 5/00 <small>(2006.01)</small>
A61B 5/01 <small>(2006.01)</small>	A61B 5/02 <small>(2006.01)</small>
A61B 5/021 <small>(2006.01)</small>	A61B 5/024 <small>(2006.01)</small>
A61B 5/0205 <small>(2006.01)</small>	A61B 5/11 <small>(2006.01)</small>
G16H 40/67 <small>(2018.01)</small>	A61B 5/28 <small>(2021.01)</small>
A61B 5/346 <small>(2021.01)</small>	G16H 40/63 <small>(2018.01)</small>

(52) Cooperative Patent Classification (CPC):

A61B 5/0006; A61B 5/0022; A61B 5/01; A61B 5/0205; A61B 5/02055; A61B 5/02125; A61B 5/02438; A61B 5/1112; A61B 5/28; A61B 5/346; A61B 5/681; A61B 5/6831; A61B 5/7207; A61B 5/7228; A61B 5/7285; (Cont.)

(86) International application number:

PCT/CA2021/050294

(87) International publication number:

WO 2021/174366 (10.09.2021 Gazette 2021/36)

(54) A SMART WRISTBAND FOR MULTIPARAMETER PHYSIOLOGICAL MONITORING

**INTELLIGENTES ARMBAND ZUR PHYSIOLOGISCHEN MULTIPARAMETERÜBERWACHUNG
BRACELET INTELLIGENT PERMETTANT UNE SURVEILLANCE PHYSIOLOGIQUE À
PARAMÈTRES MULTIPLES**

(84) Designated Contracting States:

**AL AT BE BG CH CY CZ DE DK EE ES FI FR GB
GR HR HU IE IS IT LI LT LU LV MC MK MT NL NO
PL PT RO RS SE SI SK SM TR**

(30) Priority: **06.03.2020 US 202062986199 P**

(43) Date of publication of application:
11.01.2023 Bulletin 2023/02

(73) Proprietor: **The Access Technologies
Ottawa, Ontario K2H 5Z3 (CA)**

(72) Inventors:

- **AHMAD, Saif**
Kanata, Ontario K2M 2L6 (CA)
- **GARG, Atul K.**
Kanata, Ontario K2W 1A5 (CA)

(74) Representative: **Laine IP Oy**

**Porkkalankatu 24
00180 Helsinki (FI)**

(56) References cited:

US-A1- 2017 238 819	US-A1- 2018 106 897
US-A1- 2019 059 752	US-A1- 2019 117 083

EP 4 114 252 B1

Note: Within nine months of the publication of the mention of the grant of the European patent in the European Patent Bulletin, any person may give notice to the European Patent Office of opposition to that patent, in accordance with the Implementing Regulations. Notice of opposition shall not be deemed to have been filed until the opposition fee has been paid. (Art. 99(1) European Patent Convention).

(52) Cooperative Patent Classification (CPC): (Cont.)
A61B 5/742; A61B 5/746; G16H 40/63;
A61B 2562/0219; A61B 2562/0271; G16H 50/30

Description**TECHNICAL FIELD**

5 **[0001]** In general, the present invention relates to multiparameter monitoring in humans with wearable technology, and in particular to non-invasive blood pressure (NIBP), blood oxygen saturation (SpO₂), heart rate (HR), HR variability (HRV), respiration rate (RR), temperature, arterial pulse, and electrocardiogram (ECG) monitoring utilizing an ergonomically designed smart wristband.

10 BACKGROUND

[0002] The very first wrist wearable device is the mechanical movement timekeeping wristwatch that was developed in the early 19th century.

15 **[0003]** With rapid advancements in semiconductor and computing technologies, wristwatch technology has witnessed a massive growth whereby timekeeping has been accurately and efficiently accomplished via microcontrollers, digital crystals, and electronic displays. Moreover, modern day wristwatches have become increasingly smart and multifunctional such that in addition to timekeeping, they can easily perform tasks like browsing the Internet, making a telephone call, and playing audio/video media.

20 **[0004]** More recently, smartwatches or smart wristbands have been employed for non-invasively monitoring a variety of physiological phenomena and physical activity that enables users to keep track of their health. These devices are generally provided with biosensors that contact the skin of the user when worn around the wrist. In conjunction with an analog signal conditioning circuitry and a microcontroller, these biosensors acquire a variety of physiological data like arterial pulse waveform and electrocardiogram (ECG) signals, which are then analyzed to evaluate parameters like HR and blood oxygen saturation (SpO₂). User activity is generally monitored by analyzing the data collected by an accelerometer (ACL)

25 provided in the device. Smartwatches and health bands manufactured by companies like Apple, Fitbit, Samsung, **[0005]** Garmin, OshenWatch, and those disclosed in other prior art such as US20170238819A1 and US20190059752A1 utilize the reflective photoplethysmography (PPG) technique to acquire arterial pulse waveform signals from the wrist. This technology generally comprises a photodiode (PD) or optical sensor along with closely located light emitting diodes (LEDs) that contact the skin of the wrist. When the LEDs glow, some light from the LEDs is absorbed by the skin while the remainder is reflected back. The PD picks up the reflected light that changes its intensity based on the changes in blood volume inside capillaries caused by the pumping of the blood by the heart. The signal picked up by the PD is conditioned and amplified using analog circuitry to characterize the arterial pulse waveform signal. The arterial pulse wave signal is then digitized via an analog to digital converter (ADC) by the microcontroller. Quite often, LEDs of different colors (or wavelengths) are utilized within the reflective PPG methodology to acquire multiple pulse waveform signals -

30 such that each pulse waveform signal corresponds to a specific LED color or wavelength. The acquired arterial pulse waveform signals are analyzed to evaluate and monitor parameters like HR, SpO₂, and NIBP. **[0006]** Moreover, smartwatches and health bands manufactured by companies such as Apple, Fitbit, Samsung, and those disclosed in other prior art often have the functionality to acquire an ECG signal from the wrist. To this end, a set of dry electrodes are provided on the backplate of the smartwatch while another set of dry electrodes are provided on the smartwatch face. When the user wears the smartwatch on one wrist, the backplate electrodes contact the skin of the wrist. The user then touches the smartwatch face electrodes with a finger of the other hand. This completes the ECG circuit and configures the electrodes to measure the biopotential difference between the left and right side of the body. Internally, these electrodes are connected to a differential amplifier that amplifies and conditions this biopotential difference to characterize the ECG signal. The ECG signal is then digitized via an ADC by the microcontroller. The acquired ECG signal

45 is analyzed to evaluate and monitor parameters like HR and HRV. **[0007]** Based on the ongoing discussion, it is evident that non-invasive wrist-worn physiological monitors offer the most natural, convenient, and unobtrusive method for monitoring health. However, despite all the advancements described above, wrist-worn physiological monitoring technology still seems to suffer from two major problems. These two problems are briefly described below.

50 **[0008]** The first problem is the inability of non-invasive wrist-worn monitoring technology to achieve clinical-grade accuracy and consistency for assessing various physiological parameters, especially, SpO₂ and NIBP. The main reason for this problem is perhaps the complex wrist physiology whereby arteries and capillaries are embedded deep inside a bony anatomical structure which hinders clean arterial pulse waveform data acquisition via the reflective PPG methodology. When acquired pulse waveform data is low-fidelity and noisy, accurate estimation of parameters like SpO₂ and NIBP

55 from this data becomes problematic. **[0009]** The second problem is the failure of non-invasive wrist-worn monitoring technology to conveniently and seamlessly integrate multiparameter physiological monitoring. For example, at least 6 vital signs including HR, HRV, SpO₂, NIBP, RR, and body temperature are of paramount importance for not only assessing overall health but also for

assessing various conditions like hypertension, chronic obstructive pulmonary disease (COPD), atrial fibrillation (AF), sleep apnea, heart failure (HF), and febrile events. Yet, none of the existing technologies seem to offer accurate measurement of all these parameters in a single wrist-worn device. The main reason for this problem is perhaps the fact that wrist-worn multiparameter monitoring technology is still undergoing development whereby further advancements and enhancements are forthcoming.

[0010] Therefore, the field of non-invasive wrist-worn clinical-grade multiparameter monitoring offers several opportunities for the development of ground-breaking technologies that promise to usher in a paradigm shift in the manner in which health is monitored.

SUMMARY

[0011] The present invention is directed towards non-invasive clinical-grade multiparameter monitoring. The invention is defined by the appended claims.

[0012] In one example embodiment, there is provided a non-invasive, unobtrusive, sleek, single-piece, geometric stadium-shaped wearable smart wristband related to clinical-grade continuous multiparameter physiological monitoring. The smart wristband in one example is a sealed, waterproof, and dustproof unit made from materials like thermoplastic polymers. Moreover, straps made from an elastomeric material can be provided on the device for attachment to the wrist. The smart wristband may be equipped with a microcontroller with Wi-Fi and/or Bluetooth capabilities and may utilize a rechargeable battery for power. Moreover, the smart wristband may also be provided with a 3-axis ACL that is interfaced with the microcontroller via the inter-integrated circuit (I2C) bus.

[0013] In a further example embodiment, the smart wristband backplate is provided with three custom-designed reflective PPG arterial pulse sensors. Each reflective PPG arterial pulse sensor can comprise one PD surrounded by three LEDs. The three reflective PPG arterial pulse sensors may be spread along the length of the stadium-shaped backplate which in one embodiment could be approximately 3.0" long. Each of the three custom-designed reflective PPG arterial pulse sensors can be interfaced with an analog signal conditioning and amplification circuit. Output from each of the three analog signal conditioning and amplification circuits can be connected to a separate ADC channel of the microcontroller.

[0014] Additionally, in an example embodiment, the device backplate is provided with a thermopile temperature sensor in between two of the three reflective PPG arterial pulse sensors. The thermopile temperature sensor may be interfaced with the device microcontroller via the I2C bus.

[0015] When the smart wristband is worn on the wrist, in one aspect, the length of stadium-shaped device aligns with the forearm, and the PPG and thermopile sensors contact the skin of the wrist. With this configuration, the smart wristband acquires 3-channel arterial pulse waveform data, temperature data, and ACL data, and utilizes the Wi-Fi or Bluetooth protocol to wirelessly stream this data in real-time to a mobile device (for example, smartphone, tablet, etc.) and/or a computer (for example, laptop, desktop computer, etc.) running associated software to make this data transfer possible.

Additional associated software running on the mobile device and/or computer may be configured to enable the smart wristband to leverage their respective displays to enable visualization of all incoming data. Specialized algorithms, applications, and software running on the mobile device and/or the computer are capable of analyzing the incoming data to evaluate and report various parameters including cuff-less NIBP, SpO₂, HR, RR, temperature, and user activity. Additionally, the algorithms, applications, and software running on the mobile device and/or the computer may utilize the global positioning system (GPS) capabilities of these devices to detect and report user location. Associated software running on the mobile device and/or the computer can enable storage of all information locally and/or utilize the Wi-Fi, Bluetooth, or other protocols to transfer and store this information in the cloud and/or on other external devices. All stored information can then be transferred from one point to another, utilizing the Internet or other communication protocols, thus making remote multiparameter physiological monitoring possible.

[0016] In another embodiment, the smart wristband is designed to be fully standalone whereby it is additionally equipped with a touchscreen display on its top face, an internal memory, and a GPS module. Moreover, the fully standalone smart wristband can be provided with two ECG electrodes on its backplate and a third ECG electrode on its top face that may be interfaced with an analog differential signal amplification and conditioning circuitry. The output from the analog differential signal amplification and conditioning circuitry is capable of connecting to the fourth ADC channel of the microcontroller. When the smart wristband is worn on the wrist, the PPG sensors, the backplate ECG electrodes, and the thermopile sensor contact the skin of the wrist.

[0017] Additionally, the user touches the ECG electrode on the top face of the device with a finger of other hand. With this configuration, the fully standalone smart wristband acquires 3-channel arterial pulse waveform data, single channel ECG waveform data, temperature data, ACL data, and GPS data. Associated software running on the microcontroller can be configured to enable the touchscreen display to show incoming data in real-time. Moreover, algorithms and software running on the microcontroller are capable of processing incoming data to evaluate parameters including NIBP, SpO₂, HR, HRV, RR, temperature, user activity, and user location, and various results may be presented on the touchscreen display. Other information can also be presented on the screen. The fully standalone version of the smart wristband has the

functionality to store all information locally in its internal memory. Moreover, the device is configured to optionally utilize the Wi-Fi, Bluetooth, or other protocols to transfer or stream information directly or from its internal memory to the cloud and/or to other external devices. Therefore, as described above, this functionality facilitates seamless remote multiparameter physiological monitoring.

5 **[0018]** In relation to the fully standalone smart wristband, it will be obvious to those skilled in the art that in case the user does not touch and hold the electrode provided on the device top face with a finger of the other hand, no ECG data will be acquired. In that case the device will only acquire and process 3-channel arterial pulse waveform data, temperature data, ACL data, and GPS data, and report associated parameters.

10 **[0019]** In one example, the smart wristband supports both manual and continuous monitoring. In manual monitoring, the user initiates a measurement that lasts a time period, such as 30 seconds, after which all data is analyzed, and results are reported. In continuous monitoring, the device automatically initiates a time period, such as a 30-second-long measurement every 15 minutes, analyzes data, and reports associated results. Again, it will be obvious to those skilled in the art that the duration of the measurements and their frequency can be easily modified as per desired monitoring needs.

15 **[0020]** According to the invention, the arrangement of the three reflective PPG arterial pulse sensors along the length of the backplate of the smart wristband allows measurement of an important NIBP-related parameter called pulse transit time (PTT) between the three arterial pulse waveform signals. Since the distances between the three reflective PPG arterial pulse sensors are also known, another NIBP-related parameter called pulse wave velocity (PWV) can also be easily computed. Moreover, the amplitude of each of the three arterial pulse waveform signals is also related to the NIBP. In one example, the device is calibrated or trained by building correlations between three PTT and three pulse amplitude metrics, and NIBP measured by a standard device. Once calibrated or trained, the correlation model can be used to independently evaluate and report NIBP with clinical-grade accuracy. Preprocessing of the data from the biosensors can be undertaken using various digital signal processing (DSP) techniques such as resampling and digital filtering for removing unwanted noise and preparing the data for further analyses. This can be followed by undertaking comprehensive data analysis utilizing specialized algorithms and software. The biosensors acquire a variety of physiological data such as arterial pulse waveform, electrocardiogram (ECG) signals, HR, HRV, SpO₂, NIBP, RR, body temperature, and user activity data.

20 **[0021]** In one embodiment of the smart wristband, the colors of the LEDs used in the three reflective PPG arterial pulse sensors are green (GRN1), yellow (YLW), and green (GRN2) respectively. With this configuration, utilizing different wavelengths of green (~517 nm) and yellow (~590 nm) light and their different absorption and reflection intensities by oxygenated and deoxygenated blood, two SpO₂ values (i. GRN1/YLW SpO₂ and ii. GRN2/YLW SpO₂) may be computed. The two computed SpO₂ values may be combined or fused using techniques such as arithmetic mean and weighted geometric mean to evaluate and report SpO₂ with clinical-grade accuracy.

25 **[0022]** In another embodiment of the smart wristband, the colors of the LEDs used in the three reflective PPG arterial pulse sensors are red (~660 nm), IR (~940 nm), and green (~517 nm) respectively. With this configuration, three SpO₂ values (i. red/IR SpO₂, ii. green/red SpO₂, and iii. green/IR SpO₂) may be computed as described above. Again, the computed SpO₂ values may be combined or fused using various techniques to evaluate and report SpO₂ with clinical-grade accuracy.

30 **[0023]** In a further aspect of the smart wristband, a HR value is calculated for each of the three arterial pulse waveform signals, resulting in three HR measurements per recording. These computed HR measurements may be combined using methods such as weighted mean to evaluate and report HR with clinical-grade accuracy. In another example, HRV information from the three arterial pulse wave signals and the ECG signal may be fused to evaluate and report HRV with clinical-grade accuracy.

35 **[0024]** In one example of the multiparameter smart wristband, respiratory sinus arrhythmia (RSA) induced modulations in the three arterial pulse amplitudes, three arterial peak-to-peak intervals (PPIs), and three arterial PTTs may be utilized to estimate nine RRs, which may be followed by fusion of all calculated RRs to report RR with clinical-grade accuracy.

40 **[0025]** An arterial pulse originates at the heart and then travels to the periphery of the limbs. The described multiparameter smart wristband detects pulse arrival at three distinct locations along the wrist to measure three arterial pulses and three arterial PTTs. If the device is attached on the wrist in the correct direction, the estimated PTTs will be positive, and all related parameters will be computed accurately. However, if the device is attached on the wrist in the wrong direction, that is, it is rotated by 180 degrees, the estimated PTTs will be negative, and the computation of related parameters will suffer. In one embodiment, to overcome this limitation, the smart wristband first checks the signs of the measured PTTs. If the PTTs are found to be positive, no action is taken, and the computations proceed normally. However, if PTTs are determined to be negative, a warning may be generated to inform the user to correct the direction of the attachment of the smart wristband. As an alternative to changing the placement of the wristband, any detected negative PTT values may be transformed to positive values prior to carrying out associated computations.

45 **[0026]** In one example of the multiparameter smart wristband, the LEDs in each of the three reflective PPG arterial pulse sensors are always on. This could potentially cause the LEDs to heat up and could also lead to the LEDs associated with one PD to cause interference in other PDs - leading to loss in signal quality. To mitigate this problem, in one example, the multiparameter smart wristband may control the LEDs associated with each of the three PDs via three pulse width

modulation (PWM) signals generated by three digital input/output (DIO) channels of the microcontroller. The three ADC channels interfaced with the three PDs can then be programmed to read data from a PD only when the LEDs associated with that PD are on, as determined by the duty cycles of the three PWM signals.

[0027] In one example, to enhance and standardize arterial pulse waveform signal quality and fidelity over all users, the multiparameter smart wristband utilizes the automatic gain control (AGC) technique. Here, gain of each of the three arterial pulse amplifiers may be controlled via a digital potentiometer that is also connected to the microcontroller, for example via the I2C bus. For each of the three arterial pulse waveform signals read by an ADC channel, the microcontroller may compute a peak-to-peak amplitude and accordingly alter the associated potentiometer's resistance via the I2C bus to change the corresponding amplifier's gain such that the peak-to-peak amplitude always stays above a given value, for example, 2.0 V. In a further example, the AGC technique described above may also be applied to the ECG signal to enhance and standardize its quality and fidelity over all users.

[0028] In one embodiment, the multiparameter smart wristband generates various health alerts based on the measured parameters and user activity level as determined by the ACL. For example, if the ACL data shows the subject at rest and the HR value is above 100 beats per minute (BPM), a tachycardia alert may be generated. Similarly, if the subject is resting and the NIBP value is above 140/90 mmHg, a hypertension alert may be generated.

[0029] Though this invention is described as related to a wearable multiparameter smart wristband that can be attached to a user's left or right wrist, the underlying design and principle of the invention can be extended to a wearable device that can be attached and used at any location along any of the two upper or even the two lower limbs for physiological monitoring. One example comprises the smart wristband worn and used on the left wrist. Another example comprises the device worn and used on upper the right arm. Yet another example comprises the smart wristband worn and used on the left ankle. It will be appreciated that the multiparameter smart wristband could be a smartwatch or any other similar wearable.

BRIEF DESCRIPTION OF THE DRAWINGS

[0030]

FIG. 1 illustrates the multiparameter smart wristband worn by a user on the left hand and tethered wirelessly to a tablet for monitoring data along with other external devices to which monitored data is transferred.

FIGS. 2A-2B illustrate the multiparameter smart wristband with its top face, power button, and backplate that incorporates reflective PPG arterial pulse sensors and thermopile sensor.

FIG. 3 illustrates an exploded view of the multiparameter smart wristband showing various components.

FIG. 4 illustrates an operational diagram of the multiparameter smart wristband showing several components and their various connections.

FIG. 5 illustrates a fully standalone version of the multiparameter smart wristband worn by a user on the left hand for monitoring data along with other external devices to which monitored data is wirelessly transferred.

FIG. 6 illustrates a fully standalone version of the multiparameter smart wristband worn by a user on the left hand with the index finger of the right hand touching the top face ECG electrode for monitoring data that includes ECG data along with other external devices to which monitored data is wirelessly transferred.

FIGS. 7A-7B illustrate a fully standalone version of the multiparameter smart wristband with its top face, power button, and backplate that incorporates reflective PPG arterial pulse sensors, thermopile sensor, and ECG electrodes.

FIG. 8 illustrates an exploded view of the fully standalone version of the multiparameter smart wristband showing various components.

FIG. 9 illustrates an operational diagram of the fully standalone version of the multiparameter smart wristband showing several components and their various connections.

FIGS. 10A-10B illustrate that when the multiparameter smart wristband is attached to the wrist in the correct direction, PTT values are positive.

FIGS. 11A-11B illustrate that when the multiparameter smart wristband is attached to the wrist in the incorrect

direction, PTT values are negative.

FIG. 12 illustrates the PWM technique that is utilized inside the multiparameter smart wristband for switching LEDs associated with the three PD sensors and synchronously reading data from these PD sensors.

FIG. 13 illustrates an operational diagram of the AGC scheme that is utilized inside the multiparameter smart wristband to standardize arterial pulse waveform signal quality and fidelity over all users.

FIG. 14 illustrates an operational diagram of the AGC scheme that is utilized inside the multiparameter smart wristband to standardize ECG signal quality and fidelity over all users.

FIG. 15 illustrates a flowchart depicting the method of manual and continuous monitoring accomplished by the multiparameter smart wristband.

FIG. 16 illustrates a flowchart depicting the generation of various health alerts by the multiparameter smart wristband.

FIG. 17 illustrates examples of various locations on the human body where wearables employing the underlying design and principle of the multiparameter smart wristband can be attached to undertake monitoring.

FIGS. 18A-18B illustrate the multiparameter smart wristband and the fully standalone version of the multiparameter smart wristband being charged on two different kinds of wireless charging units.

DETAILED DESCRIPTION

[0031] A preferred embodiment of the present invention will be set forth in detail with reference to the drawings, in which like reference numerals refer to like elements or method steps throughout.

[0032] **FIG. 1** illustrates one embodiment of the multiparameter smart wristband worn by a user on the left hand and tethered wirelessly to a tablet for monitoring data along with other external devices to which monitored data is transferred. In this example, the smart wristband **102** is worn by the user on the left hand **104** resulting in the contact of the biosensors on the device backplate (not shown) with the skin of the wrist. The smart wristband **102** runs embedded software and communicates wirelessly with a tablet **106** running a dedicated application to accomplish real-time data acquisition and streaming to the tablet **106** via protocols such as Wi-Fi and Bluetooth. The data transferred by the smart wristband **102** to the tablet **106** includes 3-channel arterial pulse waveform signals **108, 110, 112** acquired and streamed at a sampling rate of 100 Hz each utilizing three reflective PPG arterial pulse sensors (not shown) provided on the backplate of the smart wristband **102**, ACL data acquired and streamed at a sampling rate of 10 Hz utilizing an ACL sensor (not shown) provided inside the smart wristband **102**, and temperature data acquired and streamed at a sampling rate of 1.0 Hz utilizing a thermopile sensor (not shown) provided on the backplate of the smart wristband **102**. The dedicated application running on the tablet **106** simultaneously acquires GPS data at a sampling rate of 1.0 Hz utilizing the GPS capabilities of the tablet **106**. In this example, all acquired data is analyzed by the dedicated application running on the tablet **106** to report parameters such as NIBP, SpO₂, HR, RR, temperature, location, activity, PTT, and PVW **114**. In this embodiment of the smart wristband, the dedicated application running on the tablet **106** is capable of transferring all monitored data to other external devices **116**, such as the cloud, smartphones, and computers, thus enabling seamless remote physiological monitoring. It will be obvious to those skilled in the art that the tablet **106** can be easily replaced by other similar computing devices such as a smartphone, a laptop, and a desktop computer without affecting the overall functionality of the exemplary monitoring system. Moreover, the data sampling frequencies mentioned in the description represent only one example and can be changed as per desired monitoring requirements.

[0033] **FIGS. 2A-2B** illustrate an example of the multiparameter smart wristband with its top face, power button, and backplate that incorporates reflective PPG arterial pulse sensors and a thermopile sensor. In this embodiment, the smart wristband **102** comprises a flat top face **202** with no display. A power button **204** is utilized to switch the smart wristband **102** on and off. When the power button **204** is used to switch the smart wristband **102** on, an LED provided inside the device (not shown) turns on, the light from which is transmitted to the device's top face **202** via a light pipe (not shown) to indicate that the device is on. The backplate **206** is provided with three reflective PPG arterial pulse sensors. The first PPG arterial pulse sensor comprises a PD **208** surrounded by three LEDs **210** of a given color. Moreover, the second PPG arterial pulse sensor comprises a PD **212** surrounded by three LEDs **214** of another color. Additionally, the third PPG arterial pulse sensor comprises a PD **216** surrounded by three LEDs **218** of yet another color. The backplate **206** is also provided with a thermopile temperature sensor **220** that is placed in between the second and third PPG arterial pulse sensors. The LEDs **222** on the backplate **206** indicate the charging status of the smart wristband **102**. The screws **224** are used to fasten together the backplate **206** and top face **202** of the smart wristband **102**.

[0034] One skilled in the art will appreciate that variants exist in the arrangement and configuration of the components on the backplate **206**. For example, the thermopile temperature sensor **220** may be located between the first and second PPG arterial pulse sensors. Similarly, two or more of the LED sets **210**, **214** and **218** could have the same colour.

[0035] In one example the smart wristband **102** is in the shape of a geometric stadium of overall length 3.45", overall width 1.60", and overall thickness 0.55". Moreover, the distance between: (i) PD **208** of the first PPG arterial pulse sensor and the PD **212** of the second PPG arterial pulse sensor is 0.98", (ii) PD **212** of the second PPG arterial pulse sensor and the PD **216** of the third PPG arterial pulse sensor is 1.64", and (iii) PD **208** of the first PPG arterial pulse sensor and the PD **216** of the third PPG arterial pulse sensor is 2.62". Therefore, when the smart wristband **102** is worn on the wrist as shown in FIG. **1**, the PPG arterial pulse sensors described above measure three arterial pulse waveform signals at three distinct locations along the wrist separated by distances of 0.98", 1.64", and 2.62". Since the arterial pulse wave travels from the heart to the periphery of the limbs, the above arrangement of PPG arterial pulse sensors enable acquisition of three arterial pulses with three different pulse arrival times. These different pulse arrival times enable the computation of three PTT metrics. Moreover, since the distances between each of the three PDs are known, the computation of three corresponding PWV metrics is straightforward.

[0036] One skilled in the art will appreciate that variants exist in the sizing of the smart wristband and location of the three PPG arterial pulse sensor. It is only necessary for the three separate PPG arterial pulse sensors to be spaced apart in a manner to detect three separate arterial pulses; accordingly, the exact location of the PPG arterial pulse sensors within the backplate **206** can vary. Similarly, the size and shape of the smart wristband **102** can vary. For example, while an oblong or oval shape of a geometric stadium is preferred, one skilled in the art could configure the shape as rectangular, circular or any other shape that would accommodate three separate PPG arterial pulse sensors spaced apart in a manner to detect three separate arterial pulses.

[0037] FIG. **3** illustrates an exploded view of the example multiparameter smart wristband showing various components. In one example embodiment, the backplate **206** comprises a light barrier boundary **302** that prevents light crosstalk between various LEDs and PDs to enable acquisition of high-quality arterial pulse waveform data. In a further example embodiment, the backplate **206** is manufactured via the industrial co-moulding process whereby the backplate material is moulded using acrylonitrile butadiene styrene (ABS) while each of the window cut-outs for the PDs **208**, **212**, **216**, LEDs **210**, **214**, **218**, **222**, and thermopile sensor **220** is moulded using transparent acrylic. This process creates individualized transparent acrylic lenses that separately cover each LED, each PD, and the thermopile sensor. There are two advantages of the described co-moulding process. First, it fully encapsulates the LEDs **210**, **214**, **218**, **222**, PDs **208**, **212**, **216**, and the thermopile sensor **220** to efficiently provide waterproofing and dustproofing. Secondly and most importantly, it restricts any internal light spread within a lens to that lens only, again preventing light crosstalk between various LEDs and PDs to enable acquisition of high-fidelity arterial pulse waveform data. Other methods of manufacturing may also be used to manufacture the backplate **206**.

[0038] In the example embodiment shown in FIG. **3**, the PDs **208**, **212**, **216**, LEDs **210**, **214**, **218**, **222**, and thermopile sensor **220** are mounted (not shown) on a custom-designed printed circuit board (PCB) **304**. The power button **204** is also mounted on the PCB **304**. Other types of mountings can be contemplated by those skilled in the art.

[0039] Referring to FIG. **3**, in one embodiment, the device strap **312** may be made from elastomeric rubber. The strap **312** may be manufactured as a single piece wherein a gasket **318** is integrated with the strap **312**. The gasket portion **318** of the strap **312** helps to make the device waterproof and dustproof. The strap **312** may also be provided with a clasp **314** and holes **316** that enable the device to be conveniently fastened around the wrist to achieve a snug fit. Other arrangements of clasps, holes, and materials for formation of the device strap **312** may be used. For example, Velcro™ could be used for closure of the straps. In addition, while inclusion of the gasket **318** provides advantages, the gasket **318** is optional and the strap **312** may be manufactured without it. Furthermore, the strap may be formed of multiple pieces if required. While it is advantageous to manufacture the smart wristband as a sealed, waterproof, and dustproof unit, other configurations are envisioned that are not sealed, waterproof, and/or dustproof, depending upon the needs of the user. In addition, the strap could be formed of other material besides elastomeric rubber, such as nylon-like material or other suitable materials.

[0040] FIG. **3** also shows a rechargeable battery **306** provided inside the device. In one example, the device PCB **304** is provided with Qi wireless charging circuitry to which is attached a charging coil **308**. With this configuration, the device battery **306** is charged utilizing the Qi wireless charging protocol. The wireless charging circuitry integrated with the PCB **304** enables the device battery to be charged wirelessly with a standard wireless charger. This enables the device enclosure to be completely sealed, simplifying the waterproofing requirement. Other forms of power sources for the device can be contemplated, such as through removable and/or replaceable batteries or through wired charging.

[0041] With reference to FIG. **3**, an optional light pipe **310** is provided to carry light from the power on indication LED (not shown) provided on the PCB **304** to the top face **202** of the multiparameter smart wristband **102**. Finally, the screws **224** fasten all components together.

[0042] FIG. **4** illustrates an exemplary operational diagram of the multiparameter smart wristband showing several components and their various connections. The brightness of the three LED clusters **210**, **214**, **218** may be controlled via three resistors **402**, **404**, **406** respectively. The three PDs **208**, **212**, **216** are connected to three analog signal amplification

and conditioning circuits **408**, **410**, **412** respectively, the outputs of which are connected to three ADC channels (ADC0, ADC1, ADC3) of the microcontroller **414**. The thermopile temperature sensor **220** may be connected to the microcontroller **414** via the I2C bus. Moreover, ACL sensor **416** may also be connected to the microcontroller **414** through the I2C bus. A radio transceiver **418** along with an antenna **420** may be connected to the microcontroller **414** that enables the smart wristband to communicate wirelessly with the outside world utilizing protocols such as Wi-Fi and Bluetooth.

[0043] Referring to FIG. 1, FIG. 2B, and FIG. 4, in one embodiment, the LED cluster **210** comprises three green LEDs (D_4, D_5, D_6), the LED cluster **214** comprises three yellow LEDs (D_7, D_8, D_9), and the LED cluster **218** comprises three green LEDs (D_{10}, D_{11}, D_{12}). The three acquired pulse waveform signals can therefore be referred to as green 1 (GRN1) **108**, yellow (YLW) **110**, and green 2 (GRN2) **112** since these signals are collected by three PDs **208**, **212**, **216** that correspond to the green **210**, yellow **214**, and green **218** LED clusters. The pulse arrival time for each of the three pulse waveform signals **108**, **110**, **112** will be different. Therefore, it can be assumed that the time at which signal GRN1 **108** peaks is T_{GRN1} , the time at which signal YLW **110** peaks is T_{YLW} , and the time at which signal GRN2 **112** peaks is T_{GRN2} . The three PTTs can therefore be defined as follows:

$$PTT_{YGI} = T_{YLW} - T_{GRN1} \quad (1)$$

$$PTT_{G2Y} = T_{GRN2} - T_{YLW} \quad (2)$$

$$PTT_{G2G1} = T_{GRN2} - T_{GRN1} \quad (3)$$

[0044] Further, based on the distances between the three PDs **208**, **212**, **216** and equations (1) to (3) above, three PWVs can be defined as follows:

$$PWV_{YGI} = 0.98/PTT_{YGI} \quad (4)$$

$$PWV_{G2Y} = 1.64/PTT_{G2Y} \quad (5)$$

$$PWV_{G2G1} = 2.62/PTT_{G2G1} \quad (6)$$

[0045] Since the distances between the three PDs **208**, **212**, **216** are always fixed in the multiparameter smart wristband **102**, the resulting measurements of the PTT and PWV metrics will be standardized across all subjects. That is, any differences observed in these metrics across various subjects will be actual differences that arise due to subject physiology alone and not due to the measurement mechanism. For example, if PTT is measured using an ECG signal and an arterial pulse waveform signal measured at the index finger, the value of the measured PTT will be dependent on the physical distance between the heart (where the ECG signal originates) and the index finger (where the pulse waveform signal is measured). This physical distance will change for every subject based on characteristics like height and build. Therefore, the PTT measured via this method will not be standardized across all subjects and differences observed across subjects will also be a function of factors such as subject height and build. Moreover, to compute PWV, the above-mentioned physical distance will have to be measured or known, making the ECG-based method of PTT measurement cumbersome. On the other hand, the design of the multiparameter smart wristband **102** offers an extremely standardized and convenient method of measuring PTT and PWV.

[0046] Referring to FIG. 1, the respective amplitudes of the GRN1 **108**, YLW **110**, and GRN2 **112** pulse waveforms can be represented by A_{G1} , A_Y , A_{G2} . Similarly, the respective PPIs can be represented by PPI_{G1} , PPI_Y , PPI_{G2} .

[0047] The PTT, PWV, and pulse amplitude information obtained from the three arterial pulse waveform signals **108**, **110**, and **112** can be combined using various statistical and computational techniques to evaluate NIBP. In one embodiment, the three PTT and the three pulse amplitude metrics are combined inside a multiple regression model to determine NIBP as follows:

$$NIBP = B_0 + B_1*PTT_{YGI} + B_2*PTT_{G2Y} + B_3*PTT_{G2G1} + B_4*A_{G1} + B_5*A_Y + B_6*A_{G2} \quad (7)$$

[0048] The multiple regression model described in equation (7) is trained utilizing simultaneous measurements from the multiparameter smart wristband **102** and a standard NIBP device on various subjects to determine constants B_0 - B_6 . Once trained, the linear regression model of equation (7) may be used to evaluate and report cuff-less NIBP with clinical-grade accuracy.

[0049] In another embodiment, a log product of the three PWV and the three pulse amplitude metrics are combined inside a regression model to determine cuff-less NIBP with clinical-grade accuracy as follows:

$$NIBP = B_0 + B_1 * \log (PWV_{YG1} * PWV_{G2Y} * PWV_{G2G1} * A_{G1} * A_Y * A_{G2}) \quad (8)$$

[0050] NIBP is generally reported as two numbers, namely, systolic pressure (SP) and diastolic pressure (DP), whereby the unit of measurement is mmHg. In equations (7) and (8), the NIBP term can be replaced by either SP or DP. Since SP is different in magnitude (generally 120 mmHg) than the DP (generally 80 mmHg), separate regression models (of the type shown in equations (7) and (8)) are built for SP and DP. Once calibrated, these models may be utilized to evaluate and report cuff-less SP and DP with clinical-grade accuracy.

[0051] Calibration and training may occur using a standard peripheral BP monitor on a per subject and population cohort basis. Relationship mappings between PWV and systolic/diastolic pressure may be created using various techniques like statistical linear/nonlinear regressions and artificial neural network modeling. An advantage is that the relationship mappings can also be created using an aortic/carotid BP monitor. Therefore, after calibration and training, peripheral and/or aortic/carotid BP can be reported using PTT/PWV information obtained from the acquired PPG pulse waveform data. The device may be calibrated and trained by creating relationship mappings between pulse peaks/troughs/amplitudes and standard peripheral and/or aortic/carotid BP devices.

[0052] The multiparameter smart wristband **102** may combine the three PPIs using various statistical and computational techniques to evaluate HR with clinical-grade accuracy. In one example, a non-weighted mean is used as follows:

$$HR = 60 / [(PPI_{G1} + PPI_Y + PPI_{G2}) / 3] \quad (9)$$

[0053] Referring to equation (9), the unit of measurement of PPIs is seconds and division of 60 by the average of PPIs results in a HR reported in BPM.

[0054] In one example, the multiparameter smart wristband **102** may utilize the RSA induced modulations in the three arterial pulse amplitudes, three PPIs, and three PTTs to estimate nine RRs in breaths per minute (BRPM). This may be followed by fusion of all calculated RRs utilizing various mathematical and computational techniques to report RR with clinical-grade accuracy. Key steps of RR computation are: (i) peak detection, (ii) peak interpolation, (iii) bandpass filtering, (iv) peak detection & respiration rate extraction, and (v) fusion of all respiration rates. In one embodiment, the nine resulting RRs are aggregated by computing their weighted mean as follows:

$$RR = \frac{\sum_{i=0}^{n-1} W_{RRi} RR_i}{\sum_{i=0}^{n-1} W_{RRi}} \quad (10)$$

[0055] In equation (10), the weights are represented by W_{RRi} whereby the total number of RRs are $n = 9$. In this manner, aggregated RR may be evaluated and reported in BRPM with clinical-grade accuracy.

[0056] In one embodiment the smart wristband **102**, utilizes: (i) the ratio between GRN1 and YLW pulse waveform signals to evaluate a first SpO_2 value and (ii) the ratio between GRN2 and YLW pulse waveform signals to evaluate a second SpO_2 value. In another example, the multiparameter smart wristband **102** employs red, IR, and green LED clusters inside its three PPG arterial pulse sensors and utilizes: (i) the ratio between red and IR pulse waveform signals to evaluate a first SpO_2 value, (ii) the ratio between green and red pulse waveform signals to evaluate a second SpO_2 value, and (iii) the ratio between green and IR pulse waveform signals to evaluate a third SpO_2 value. The evaluated SpO_2 values are then fused utilizing various statistical techniques to report SpO_2 as a percentage with clinical-grade accuracy. The three SpO_2 values obtained from the red, IR, and green pulse waveform signals can be represented as S_{RIR} , S_{GR} , and S_{GIR} . In one example, the smart wristband **102**, may use an unweighted geometric mean to aggregate these three SpO_2 values as follows:

$$SpO_2 = \sqrt[3]{S_{RIR} * S_{GR} * S_{GIR}} \quad (11)$$

[0057] With reference to FIG. 1 and FIGS. 2A-2B, appropriate placement of the three custom-designed reflective PPG arterial pulse sensors along the backplate **206** of the smart wristband **102** facilitates the measurement of arterial pulses at three distinct locations **208**, **212**, **216** along the wrist, thus reducing positional dependency of pulse measurement on the wrist and increasing the probability of collection of good quality signals at one or more locations. For example, if the quality of the first arterial pulse waveform signal **108** is not good, there is a probability that the quality of the second arterial pulse waveform signal **110** is better, and so on. The fusion of information from all three pulse waveform signals **108**, **110**, **112** as

described above thus results in the estimation of parameters such as HR, RR, SpO₂, and NIBP with clinical-grade accuracy.

5 [0058] FIG. 5 illustrates an example of a fully standalone version of the multiparameter smart wristband worn by a user on the left hand for monitoring data along with other external devices to which monitored data is optionally wirelessly transferred or streamed. In this example the multiparameter smart wristband 102 is fully standalone and is worn on the left hand 104. The multiparameter smart wristband 102 comprises a touchscreen display 502 on its top face 202 for visualizing signals and results and giving inputs to the device. The device 102 may also be provided with two ECG electrodes on its backplate (not shown) and one ECG electrode 504 on its top face 202. The fully standalone version of the multiparameter smart wristband 102 has wireless capabilities like Wi-Fi and Bluetooth so that it can conveniently (optionally) transmit all monitored data to other external devices 116. In this embodiment of the invention, all data acquisition, analysis, storage, and transmission tasks may be performed by the microcontroller (not shown) that runs dedicated embedded software.

10 [0059] FIG. 6 illustrates an embodiment of a fully standalone version of the multiparameter smart wristband worn by a user on the left hand with the index finger of the right hand touching the top face ECG electrode for monitoring data that includes ECG data along with other external devices to which monitored data is optionally wirelessly transferred. The device 102 is worn on the left hand 104 such that the ECG electrodes on the backplate (not shown) contact the skin. Additionally, the ECG electrode 504 provided on the front face 202 is touched by the index finger of the right hand 602 to complete the ECG circuit. With this configuration, the multiparameter smart wristband 102 additionally acquires a single channel ECG waveform signal. In FIG. 6, a zoomed version of the touchscreen display 502 is shown whereby two arterial pulse waveform signals 110, 112 and an ECG waveform signal 604 are being monitored. In one embodiment, the device microcontroller (not shown) may detect ECG R-peaks to compute and report HR and HRV metrics with clinical-grade accuracy. Again, all monitored information may be wirelessly transferred to other external devices 116. Finally, all data acquisition, analysis, storage, and transmission tasks may be handled by the microcontroller (not shown) running dedicated embedded software.

15 [0060] FIGS. 7A-7B illustrate an example of a fully standalone version of the multiparameter smart wristband with its top face, power button, and backplate that incorporates reflective PPG arterial pulse sensors, thermopile sensor, and ECG electrodes. In this example, the device top plate 202 is additionally provided with a touchscreen display 502 and an ECG electrode 504. Moreover, the device backplate 206 is additionally provided with two ECG electrodes 702, 704.

20 [0061] FIG. 8 illustrates an exploded view of the fully standalone version of the multiparameter smart wristband showing various components. In this example of the invention, the top plate 202 additionally accommodates the touchscreen display 502 and an ECG electrode 504. Moreover, the backplate 206 additionally incorporates two ECG electrodes 702, 704. In this example embodiment, due to the addition of the touchscreen display 502 on the top face 202, the charging coil 308 associated with the Qi wireless charging circuitry is provided just above the backplate 206. The charging coil 308 can be located anywhere within the multiparameter smart wristband in which it will provide charging power to the rechargeable battery 306.

25 [0062] FIG. 9 illustrates an operational diagram of the fully standalone version of the multiparameter smart wristband showing several components and their various connections. Here, the microcontroller 414 may be additionally interfaced with a GPS module 902 via a UART bus, a touchscreen display 502, and a memory module 904. The first ECG electrode 702 provided on the device backplate 206 is a left-side electrode that may be connected to the first input of an analog differential amplifier 906 whereas the second ECG electrode 704 provided on the device backplate 206 is a driven electrode that may be connected to a driving amplifier 908. The ECG electrode 504 provided on the device top face 202 is a right-side electrode that may be connected to the second input of an analog differential amplifier 906. In reference to FIG. 9, the microcontroller 414 may run dedicated embedded software to independently monitor three arterial pulse waveform signals, one ECG waveform signal, user activity, and user location. Moreover, the microcontroller 414 may also run dedicated embedded software to independently analyze all data to report parameters like NIBP, SpO₂, HR, HRV, RR, temperature, user activity, and user location. The microcontroller 414 may also store information inside the memory module 904 as required. Finally, the microcontroller 414 transmits information wirelessly to the outside world via the radio transceiver 418 and antenna 420.

30 [0063] With reference to FIG. 1, Fig. 4, FIG. 6, and FIG. 9, in one embodiment, data from the ACL 416, which is synchronously collected along with the arterial pulse waveform 108, 110, 112 and ECG waveform 604 data, may be used to remove noise like motion artifacts from these signals to further enhance the accuracy of HR, HRV, RR, SpO₂, and NIBP estimation.

35 [0064] FIGS. 10A-10B illustrate that when the multiparameter smart wristband is attached to the wrist in the correct direction, PTT values are positive. With reference to FIGS. 10A-10B, the smart wristband 102 is attached on the left hand 104 in the correct and expected direction. As discussed earlier, the arterial pulse wave travels unidirectionally from the heart towards the fingers of the hand 104. Therefore, the acquired GRN1 signal 1002 leads the acquired GRN2 signal 1004 since the GRN1 PPG arterial pulse sensor (not shown) is farther away from the periphery (fingers) of the left hand 104 and the GRN2 PPG arterial pulse sensor (not shown) is closer to the periphery (fingers) of the left hand 104 underneath the device 102. In this scenario, the PTTs computed by subtracting the temporal locations of the peaks of the GRN1 signal

1002 from the temporal locations of the peaks of the GRN2 signal **1004** result in positive values **1006**.

[0065] FIGS. **11A-11B** illustrate that when the multiparameter smart wristband is attached to the wrist in the incorrect direction, PTT values are negative. In this scenario, the PTTs computed by subtracting the temporal locations of the peaks of the GRN1 signal **1002** from the temporal locations of the peaks of the GRN2 signal **1004** result in negative values **1102**.

According to the invention, this phenomenon is utilized to automatically detect whether the user has attached the device **102** on the wrist in the correct direction or not. Moreover, when an incorrect attachment is detected and the computed PTT values are negative, they may be automatically corrected to positive values. In addition to the foregoing, or alternatively, if PTT values of less than 0 are detected, it implies that these values are negative and an alert "Smart wristband attached in the correct direction" may be generated for the user. Moreover, even if the wristband is not adjusted in the proper direction, the negative PTT values may be corrected by multiplying them by negative 1. Then the corrected PTT values may be used for further computations as needed. An example of a simplified iOS Swift code that analyzes negative PTT values **1102** to automatically detect and alert for wrong attachment of the multiparameter smart wristband **102** on the wrist and also corrects these values is presented below:

Smart Wristband Attachment Direction Detection and PTT Correction var PTT = [-263, -253, -254, -250, -261]

[0066]

```

var negativeCount = 0
for i in 0...(PTT.count-1) {
  if (PTT[i] < 0) {
    negativeCount += 1
  }
}
if (negativeCount>0) {
  print ("Smart wristband attached in the incorrect direction")
  for i in 0...(PTT.count-1) {
    PTT[i] = -PTT[i]
  }
} else {
  print ("Smart wristband attached in the correct direction")
}
print ("Corrected PTTs =", PTT)

```

[0067] FIG. **12** illustrates an exemplary PWM technique that may be utilized inside the multiparameter smart wristband for switching LEDs associated with the three PD sensors and synchronously reading data from these PD sensors. In this example, the three LED clusters **210, 214, 218** are switched on and off utilizing three PWM signals **1202, 1204, 1206** that are generated by three DIO channels (not shown) of the microcontroller **414**. The three ADC channels (ADC0, ADC1, ADC2) of the microcontroller **414** that are interfaced with the three PDs **208, 212, 216** may be programmed to read a data sample only when the corresponding PWM signal is high. In this example, each LED cluster is on for 1100 ms and off for 8900 ms, and a data read occurs exactly at the middle of the on period. Moreover, there is a phase difference of 1600 ms between the three PWM signals **1202, 1204, 1206**. This particular PWM scheme therefore results in a data sampling rate of 100 Hz each for the three acquired arterial pulse waveform signals. As discussed earlier, the described PWM technique allows that: (i) the LEDs do not heat up and (ii) the LEDs associated with one PD do not cause interference in other PDs. The described PWM technique therefore may provide the acquisition of high-quality clinical-grade arterial pulse waveform data. Other PWM techniques having different data sample rates, on/off periods and phase differences may also be used.

[0068] FIG. **13** illustrates an operational diagram of an exemplary AGC scheme that is utilized inside the multiparameter smart wristband to standardize arterial pulse waveform signal quality and fidelity over all users. In this example, the signal from the GRN1 PD **208** is amplified by the amplifier **408** after which it is fed to the ADC channel ADC0 of the microcontroller **414**. The gain of the differential amplifier **408** may be controlled by an I2C potentiometer R_6 **1302** that is connected to an I2C port of the microcontroller **414**. The non-inverting gain of the amplifier **408** may be governed by R_5 **1304** and the I2C potentiometer R_6 **1302** and represented as $G = (1 + R_5/R_6)$. In one embodiment, the microcontroller **414** computes a peak-to-peak amplitude of the GRN1 arterial pulse waveform signal and automatically alters the resistance of R_6 **1302** via the I2C bus to change the gain of the amplifier **408** such that the peak-to-peak amplitude of the GRN1 signal always stays above 2.0 V. This AGC technique may be employed to standardize all three arterial pulse waveform signals acquired from the three PDs **208, 212, 216**, resulting in the acquisition of clinical-grade high-fidelity arterial pulse waveform data from all users.

[0069] In another embodiment, three sliders may be provided on the display **114** of the tethered mobile device **106** and/or on the touchscreen display **502** of the smart wristband **102**. These three sliders may be in communication with the three I2C potentiometers that control the gains of the three PD amplifiers **408, 410, 412**. In one example, the user eyeballs

the incoming data and then manually adjusts the gain of the three arterial pulse waveform signals using these three sliders to obtain clinical-grade high-fidelity arterial pulse waveform data.

[0070] FIG. 14 illustrates an operational diagram of an example AGC scheme that is utilized inside the multiparameter smart wristband to standardize ECG signal quality and fidelity over all users. The gain control amplifier in this embodiment is an I2C potentiometer R₁₀ 1402 that controls the gain of the ECG differential amplifier 906 in conjunction with R₁₁ 1404. Again, the gain may be controlled automatically via the microcontroller 414 and/or manually via a user interface (UI) slider (as described above for arterial pulse waveform data) to obtain high-fidelity ECG signals for all users.

[0071] FIG. 15 illustrates an exemplary flowchart depicting the method of manual and continuous monitoring accomplished by the multiparameter smart wristband. The device is switched on at block 1502. At block 1504, if the monitoring mode is not continuous, then the program flow goes to block 1506 where temperature data is collected using the thermopile sensor 220 for 10 seconds. Then block 1508 checks whether the temperature data collected is valid or not and demands recollection of the temperature data via block 1506 until valid temperature data is collected. If block 1508 determines that the collected temperature data is valid, the program flow proceeds to block 1510 that checks whether ECG on demand is on or off. The ECG on demand block 1510 essentially checks whether the user is touching the ECG electrode 504 on the device top face 202 with a finger of the other hand without which ECG data acquisition cannot be accomplished. If at block 1510, ECG on demand is on, then all data including ECG data is collected for 30 seconds or other time period at block 1520. Block 1522 then checks if collected data is valid - if not valid, program flow goes back to the ECG on demand block 1510, otherwise program flow goes to block 1524 that analyzes data, calculates and displays parameters, and optionally sends information to other external devices 116. Once a manual monitoring session is completed, block 1526 switches off the device. If ECG on demand at block 1510 is off, the program flow proceeds in a similar manner through blocks 1512, 1514, 1516, 1518, without ECG data acquisition. At block 1504, if the monitoring mode is continuous, then the program flow proceeds in a similar manner through blocks 1528, 1530, 1532, 1534, 1536 without ECG data acquisition. The block 1538 instructs the program to pause for 15 minutes after which the flow goes back to block 1504. If block 1504 maintains the monitoring mode as continuous, data is automatically collected, analyzed, displayed, and transmitted every 15 minutes.

[0072] FIG. 16 illustrates an example flowchart depicting the generation of various health alerts by the multiparameter smart wristband. At block 1602, the program prepares physiological and ACL data for analysis. Most normal ranges of physiological parameters are defined for the resting state. Therefore, at block 1604 the program utilizes the ACL information to detect if the subject is at rest or not. If block 1604 detects that the subject is not at rest, no alerts are generated as defined by block 1606. If block 1604 determines that the subject is at rest, the program flow goes to blocks 1608, 1610, 1612, 1614, 1616 that determine whether various physiological parameters are within their clinically specified normal ranges or not. If the physiological parameters are within the desired ranges, then no alerts are generated as described by blocks 1620, 1624, 1628, 1632, 1636. Conversely, if the physiological parameters are outside the desired ranges, then alerts are generated as described by blocks 1618, 1622, 1626, 1630, 1634. For example, if the resting HR is outside the 60-100 BPM range as defined by block 1608, then a bradycardia or tachycardia alert is generated as described by block 1618.

[0073] FIG. 17 illustrates examples of various locations on the human body where wearables employing the underlying design and principle of the multiparameter smart wristband can be attached to undertake monitoring. As illustrated in 1702, the multiparameter smart wristband 102 can be worn around the left wrist for monitoring data. As illustrated in 1704, the multiparameter smart wristband 102 can be worn around the right upper arm for monitoring data. Finally, as illustrated in 1706, the multiparameter smart wristband 102 can be worn around the left ankle for monitoring data. These examples demonstrate that the disclosed multiparameter smart wristband 102 and/or similar wearable devices can be attached at various locations along the 4 limbs to accomplish manual or continuous multiparameter physiological monitoring.

[0074] FIGS. 18A-18B illustrate the multiparameter smart wristband and the fully standalone version of the multiparameter smart wristband being charged on two different kinds of wireless charging units. In one example, the multiparameter smart wristband 102 that does not have a touchscreen display is charged upside down with its top face touching the top of Qi wireless charger 1802. With this charging configuration, the charging status indicator LEDs 222 are conveniently visible to the user. In another example, the multiparameter smart wristband 102 with a touchscreen display is charged with its backplate touching the top of a Qi wireless charger 1804. With this charging configuration, the charging status indicator LED 1806 provided on the wireless charger 1804 is conveniently visible to the user.

[0075] The specific examples provided herein relate to a multiparameter smart wristband for physiological monitoring, however, the materials, methods of application and arrangements of the invention can be varied. For example, any time periods, frequencies, and sampling rates mentioned here are variable and can be adjusted. As a further variant, the biosensors could be snugly fitted flush with the backplate. In another variant, a waterproof epoxy could be used to internally seal the PDs and/or LEDs, which would assist with water resistance.

[0076] In another variation, the custom PCB may be provided with an accelerometer chip that communicates with the microcontroller via the I2C bus. The microcontroller may acquire X, Y, Z axes data related to subject motion and posture using the accelerometer chip via the I2C bus. Since the accelerometer data may be synchronously collected with PPG

waveform data, it may also be used to remove noise like motion artifacts from PPG data to increase accuracy of PR, SpO₂ and BP estimation. The accelerometer and related algorithms may be used to track and report motion and its intensity. Moreover, this information may also be used to remove biosensor noise that is created by motion artifacts to enhance overall measurement accuracy.

5 [0077] In a further variation, a thermistor or other temperature sensor could be used instead of a thermopile sensor. The voltage across the thermistor that characterizes the body temperature may be acquired by an ADC on the microcontroller. Voltage data collected from the thermistor may be used to determine the thermistor's resistance. Then, the thermistor's resistance-temperature look-up table may be used to report body temperature.

10 [0078] In yet a further variation, the microcontroller may time stamp acquired data and wirelessly stream this data to a base station, such as a tablet or smartphone via a Bluetooth chip which may be connected to a UART port. The microcontroller on the device may be further provided with a sync-able real-time clock (RTC). All date-stamped data can be reported and stored in comma-separated value (CSV) format whereby the first column exports the time stamps while subsequent columns report values of PPG waveform and other data. Time stamping could be accomplished using the microcontroller RTC in conjunction with the base station clock.

15 [0079] In yet a further variation, the ECG electrode locations and numbers can vary. For example, the multiparameter smart wristband can have one ECG electrode on the bottom and two ECG electrodes on the top. In such a configuration, one ECG electrode on the backplate would contact the skin, while two ECG electrodes provided on the front face would be touched by the index finger to complete the ECG circuit.

20 [0080] Various programming languages such as assembly language, embedded C, C, Java, Swift, and Python may be used to develop software for accomplishing data analysis on the microcontroller and base station or external devices. The software could provide functionality such that data analysis can be done in real time on live data as well as on a post-hoc basis on stored data.

25 [0081] Furthermore, a structured software development kit (SDK) may be architected to enable third parties to develop software for accessing measurements from the data. The SDK documentation could outline the protocol, interface, commands, and system responses. A dynamically linked library could also be constructed and included with the SDK.

[0082] The components could be selected such that a unit cost of less than \$20 (for on-patient portion excluding GPS and display) for large quantities ($\geq 1K$) is possible. Hence the device can be realized and fabricated as a low-cost yet effective multiparameter physiological monitor.

30 [0083] As a further variant, the smart wristband 102 of FIGS. 1 to 4 may incorporate the ECG sensors therein and further monitor ECG signals.

[0084] The scope of the claims should not be limited by the preferred embodiments set forth in the examples but should be given the broadest interpretation consistent with the description as a whole.

35 Claims

1. A smart wristband (102) for multiparameter physiological monitoring comprising:

a backplate (206);

40 multiple biosensors including at least three photoplethysmography, PPG, sensors configured to contact skin of a user in at least three separate locations (208, 212, 216); and

a microcontroller (414) in communication with the biosensors and configured to determine multiple vital signs from data from the biosensors, wherein the microcontroller (414) is configured to receive at least three arterial pulse waveform signals via the at least three PPG sensors; and

45 a transceiver (418) configured for wireless communication, wherein the microcontroller (414) is configured to utilize the transceiver (418) to send the vital signs or data to an external device (106, 116);

wherein the at least three PPG sensors are located across a length of the backplate (206), separated from each other by predetermined distances, and collectively configured to measure the at least three arterial pulse waveform signals each with different pulse arrival times from the at least three separate locations (208, 212, 216) on the skin of the user, enabling measurement of at least three pulse transit time, PTT, signals, and wherein the microcontroller (414) is configured to compute at least three PTT metrics using the different pulse arrival times and the predetermined distances, and to thereafter use the at least three PTT metrics to calculate at least one parameter of the user; and

50 wherein the external device (106, 116) and/or the microcontroller (414) are configured to automatically detect and correct for a wrong attachment of the smart wristband (102) on a limb (104) of the user via identification of negative pulse transit times in the at least three PTT signals obtained from the at least three PPG sensors, and if the negative pulse transit times are identified, to provide a wrong attachment alert and/or correct the negative pulse transit times by multiplying the negative pulse transit times in the at least three PTT signals by -1.

2. The smart wristband (102) of claim 1 wherein each respective one of the at least three PPG sensors includes at least three light emitting diodes, LEDs, (214) and at least one photodiode, PD, sensor (208), and wherein the biosensors further optionally comprise a temperature sensor (220), wherein temperature sensor data from the temperature sensor (220) is optionally aggregated to report body temperature.
- 5
3. The smart wristband (102) of claim 1 or 2, further comprising a top face (202), wherein the biosensors further comprise at least three ECG electrodes (504, 702, 704), wherein two ECG electrodes (702, 704) are in the backplate (206), while one ECG electrode (504) is in the top face (202), and wherein one of the two ECG electrodes in the backplate (206) is optionally a driven electrode.
- 10
4. The smart wristband (102) of any one of claims 1 to 3, wherein the biosensors measure the vital signs and the vital signs include heart rate, HR, heart rate variability, HRV, blood oxygen saturation, SpO₂, non-invasive blood pressure, NIBP, respiration rate, RR, body temperature and arterial pulse, along with electrocardiogram, ECG, monitoring.
- 15
5. The smart wristband (102) of any one of claims 1 to 4, wherein the microcontroller is configured to utilize the transceiver to send the vital signs or raw data in real-time to one or more external devices (106), and wherein the one or more external devices (106) are configured to display data, store data, and/or transmit data to other external devices (116).
- 20
6. The smart wristband (102) of any one of claims 1 to 5, further comprising an accelerometer sensor (416), wherein the microcontroller (414) acquires user activity data, and/or motion data via the accelerometer sensor (416).
- 25
7. The smart wristband (102) of any one of claims 1 to 6, wherein the microcontroller (414) and/or external device (106, 116) are configured to acquire at least three arterial pulse waveform signals via the at least three PPG sensors, and wherein the microcontroller (414) and/or external device (106, 116) are configured to
- 30
- analyze the at least three arterial pulse waveform signals to compute at least three pulse transit time, PTT,, at least three pulse wave velocities, PWV,, and at least three pulse amplitude metrics and combines the at least three PTT, the at least three PWV, and the at least three pulse amplitude metrics to evaluate and report at least one non-invasive blood pressure, NIBP, parameter of the user;
- 35
- analyze the at least three arterial pulse waveform signals to compute at least three peak-to-peak interval, PPI, metrics and combines the at least three PPI metrics to evaluate and report a heart rate, HR, parameter of the user; analyze respiratory sinus arrhythmia, RSA, induced modulations in amplitudes of the at least three pulse waveform signals, the at least three PPI signals, and the at least three PTT signals to compute at least nine respiration rate, RR, metrics, and combine the at least nine RR metrics to evaluate and report an RR parameter of the user;
- 40
- analyze the at least three arterial pulse waveform signals to compute at least two blood oxygen saturation, SpO₂, metrics and combine the at least two blood SpO₂ metrics to evaluate and report an SpO₂ level of the user; analyze accelerometer data to accurately report user activity level; and optionally utilize global positioning system, GPS, capabilities to accurately report a location of the user, wherein the at least one parameter of the user includes the at least one NIBP parameter, the HR parameter, the RR parameter, and/or the SpO₂ level of the user.
- 45
8. The smart wristband (102) of any one of claims 1 to 7, further comprising a GPS module (902), a memory module (904), and a touchscreen display (502), wherein the microcontroller (414) is configured to acquire GPS data via the GPS module (902) and analyze the GPS data to accurately report a location of the user, and wherein the microcontroller (414) is optionally configured to display data, store data, receive user input via the touchscreen display (502) and/or transmit data to one or more other external devices (116).
- 50
9. The smart wristband (102) of claim 3, wherein the microcontroller (414) is configured to acquire an ECG waveform signal via the at least three ECG electrodes (504, 702, 704) whenever two of the at least three ECG electrodes contact the skin of the user on one side of the body relative to the heart of the user and one of the at least three electrodes also contacts the skin of the user on the other side of the body relative to the heart of the user, and wherein the microcontroller (414) and/or an external device (106, 116) are configured to analyze the ECG waveform signal to report the at least one parameter of the user, the at least one parameter including the HR and an HR variability, HRV, of the user.
- 55
10. The smart wristband (102) of any one of claims 1 to 9, further comprising a top face (202) and a strap (312), wherein the strap (312) includes a gasket (318) that is sealed around the backplate (206), the top face (202), the microcontroller

(414) and the biosensors, wherein the strap (312) is optionally made of elastomeric material and configured as a single piece.

- 5 11. The smart wristband (102) of any one of claims 1 to 10, wherein the microcontroller (414) is configured to perform manual and/or automatic intermittent and/or continuous physiological monitoring as per a user specified monitoring frequency and wherein the microcontroller (414) is optionally configured to generate health alerts based on the multiple vital signs obtained from the data from the biosensors.
- 10 12. The smart wristband (102) of claim 2, wherein the backplate (206) comprises light barriers between all of the at least three LEDs (214) and all of the at least one PD sensor (208) of the at least three PPG sensors, and further comprises individual transparent lenses to optically isolate and physically encapsulate each of the at least three LEDs (214) and the at least one PD sensor (208) for enhancing arterial pulse waveform data quality, and for protecting the components at least three LEDs (214) and the at least one PD sensor (208) from dust, moisture, and mechanical damage, wherein the backplate (206) is optionally manufactured utilizing an industrial co-moulding process and optionally formed from acrylonitrile butadiene styrene, ABS,, while each of the individual transparent lenses is optionally moulded using transparent materials.
- 15 13. The smart wristband (102) of any one of claims 1 to 12, wherein the microcontroller (414) is configured to acquire at least three arterial pulse waveform signals via the at least three PPG sensors and utilize automatic gain control, AGC, to standardize quality and fidelity of the three arterial pulse waveform signals over all users, wherein gains of the three arterial pulse waveform signals are controlled automatically by the microcontroller (414), or the gains are controlled manually by the user by varying sliders on a user interface, UI, that are in communication with the microcontroller (414).
- 20 14. The smart wristband (102) of any one of claims 1 to 13, further comprising electrocardiogram, ECG, electrodes, wherein the microcontroller (414) is configured to utilize automatic gain control, AGC, circuitry to standardize quality and fidelity of an ECG signal from the ECG electrodes over all users of the smart wristband (102), wherein a gain of the ECG signal is controlled automatically by the microcontroller (414), or the gain is controlled manually by the user by varying a slider on a user interface.
- 25 15. The smart wristband (102) of claim 2, wherein the microcontroller (414) is configured to utilize pulse width modulation, PWM, technique to control the at least three LEDs (214) of the at least three PPG sensors and synchronously read data from the at least one PD sensor (208) to minimize interference between unassociated LEDs and PDs and to prevent the LEDs (214) from heating up.
- 30 16. The smart wristband (102) of any one of claims 1 to 15, further comprising an accelerometer sensor (416), wherein the microcontroller (414) acquires user activity data via the accelerometer sensor (416); wherein the microcontroller (414) is configured to acquire the at least three arterial pulse waveform signals via the at least three PPG sensors, and wherein the microcontroller (414) uses synchronously collected data from the accelerometer sensor (416) to remove noise from the at least three arterial pulse waveform signals to further increase accuracy of evaluation of at least one parameter, the at least one parameter including a heart rate, HR,, a heart rate variability, HRV,, a respiration rate, RR,, a blood oxygen saturation, SpO₂, level, and/or a non-invasive blood pressure, NIBP, of the user.
- 35 17. The smart wristband (102) of any one of claims 1 to 16, wherein the microcontroller (414) is configured to acquire an ECG waveform signal via the at least three ECG electrodes, and wherein the microcontroller (414) uses synchronously collected data from an accelerometer sensor (416) to remove noise from the ECG waveform signal to further increase accuracy of evaluation of the at least one parameter, the at least one parameter including a heart rate, HR, a heart rate variability, HRV,, and/or a respiration rate, RR, of the user.
- 40 18. The smart wristband (102) of any one of claims 1 to 17, wherein the data received by the external device (106, 116) is analyzed by a software application running on the external device (106, 116) to report parameters such as NIBP, SpO₂, HR, RR, temperature, location, activity, PTT, and PWV.
- 45 50 55

Patentansprüche

1. Intelligentes Armband (102) zur physiologischen Multiparameterüberwachung, umfassend:

eine Rückplatte (206);

mehrere Biosensoren, die mindestens drei Photoplethysmographie-, PPG-, Sensoren, die so konfiguriert sind, dass sie Haut eines Benutzers an mindestens drei verschiedenen Stellen (208, 212, 216) berühren; und eine Mikrosteuereinheit (414) beinhalten, die mit den Biosensoren kommuniziert und so konfiguriert ist, dass sie mehrere Vitalzeichen aus den Daten der Biosensoren bestimmt, wobei die Mikrosteuereinheit (414) so konfiguriert ist, dass sie mindestens drei arterielle Pulswellenformsignale über die mindestens drei PPG-Sensoren empfängt; und

ein für die drahtlose Kommunikation konfigurierter Sendeempfänger (418), wobei die Mikrosteuereinheit (414) so konfiguriert ist, dass sie den Sendeempfänger (418) benutzt, um die Vitalzeichen oder Daten an ein externes Gerät (106, 116) zu senden;

wobei die mindestens drei PPG-Sensoren über die gesamte Länge der Rückenplatte (206) angeordnet sind, durch vorbestimmte Abstände voneinander getrennt sind und gemeinsam so konfiguriert sind, dass sie die mindestens drei arteriellen Pulswellenformsignale mit jeweils unterschiedlichen Pulsankunftszeiten von den mindestens drei separaten Stellen (208, 212, 216) auf der Haut des Benutzers messen, wodurch die Messung von mindestens drei Pulslaufzeit-, signalen ermöglicht wird, und wobei die Mikrosteuereinheit (414) so konfiguriert ist, dass sie mindestens drei PTT-Metriken unter Verwendung der unterschiedlichen Pulsankunftszeiten und der vorbestimmten Abstände berechnet und anschließend die mindestens drei PTT-Metriken verwendet, um mindestens einen Parameter des Benutzers zu berechnen; und

wobei die externe Vorrichtung (106, 116) und/oder die Mikrosteuereinheit (414) so konfiguriert sind, dass sie eine falsche Anbringung des intelligenten Armbands (102) an einem Körperteil (104) des Benutzers automatisch durch Identifizierung negativer Pulslaufzeiten in den mindestens drei PTT-Signalen erkennen und korrigieren, die von den mindestens drei PPG-Sensoren erhalten werden, und wenn negative Pulslaufzeiten identifiziert werden, eine Warnung wegen falscher Anbringung ausgeben und/oder die Laufzeiten der negativen Pulse korrigieren, indem Sie die Sendezeiten der negativen Pulse in den mindestens drei PTT-Signalen mit -1 multiplizieren.

2. Intelligentes Armband (102) nach Anspruch 1, wobei jeder der mindestens drei PPG-Sensoren mindestens drei Leuchtdioden, LEDs, (214) und mindestens einen Fotodiodensensor, PD-Sensor, (208) beinhaltet, und wobei die Biosensoren optional weiter einen Temperatursensor (220) umfassen, wobei die Daten von dem Temperatursensor (220) optional aggregiert werden, um die Körpertemperatur anzugeben.

3. Intelligentes Armband (102) nach Anspruch 1 oder 2, weiter umfassend eine Oberseite (202), wobei die Biosensoren weiter mindestens drei EKG-Elektroden (504, 702, 704) umfassen, wobei sich zwei EKG-Elektroden (702, 704) in der Rückplatte (206) befinden, während sich eine EKG-Elektrode (504) in der Oberseite (202) befindet, und wobei eine der beiden EKG-Elektroden in der Rückplatte (206) optional eine Ansteuerelektrode ist.

4. Intelligentes Armband (102) nach einem der Ansprüche 1 bis 3, wobei die Biosensoren die Vitalzeichen messen und die Vitalzeichen Herzfrequenz, HR, Herzfrequenzvariabilität, HRV, Blutsauerstoffsättigung, SpO₂, nicht-invasiven Blutdruck, NIBP, Atemfrequenz, RR, Körpertemperatur und arteriellen Puls beinhalten, gemeinsam mit einer Überwachung durch Elektrokardiogramm, EKG.

5. Intelligentes Armband (102) nach einem der Ansprüche 1 bis 4, wobei die Mikrosteuereinheit so konfiguriert ist, dass sie den Sendeempfänger nutzt, um die Vitalzeichen oder Rohdaten in Echtzeit an ein oder mehrere externe Vorrichtungen (106) zu senden, und wobei die externe(n) Vorrichtung(en) (106) so konfiguriert sind, dass sie Daten anzeigen, Daten speichern und/oder Daten an andere externe Vorrichtungen (116) übertragen.

6. Intelligentes Armband (102) nach einem der Ansprüche 1 bis 5, weiter umfassend einen Beschleunigungssensor (416), wobei die Mikrosteuereinheit (414) Benutzeraktivitätsdaten und/oder Bewegungsdaten über den Beschleunigungssensor (416) erfasst.

7. Intelligentes Armband (102) nach einem der Ansprüche 1 bis 6, wobei die Mikrosteuereinheit (414) und/oder die externe Vorrichtung (106, 116) so konfiguriert sind, dass sie mindestens drei arterielle Pulswellenformsignale über die mindestens drei PPG-Sensoren erfassen, wobei die Mikrosteuereinheit (414) und/oder externen Vorrichtungen (106, 116) konfiguriert sind, um

die mindestens drei arteriellen Pulswellenformsignale zu analysieren, um mindestens drei Pulslaufzeiten, PTT, mindestens drei Pulswellengeschwindigkeiten, PWV, und mindestens drei Pulsamplitudenmetriken zu berechnen, und die mindestens drei PTT-, die mindestens drei PWV- und die mindestens drei Pulsamplitudenmetriken

zu kombinieren, um mindestens einen nicht-invasiven Blutdruckparameter, NIBP, des Benutzers auszuwerten und anzugeben;

die mindestens drei arteriellen Pulswellenformsignale zu analysieren, um mindestens drei Peak-to-Peak-Intervall-, PPI-, Metriken zu berechnen, und die mindestens drei PPI-Metriken zu kombinieren, um einen Herzfrequenzparameter, HR, des Benutzers auszuwerten und anzugeben;

die durch die respiratorische Sinusarrhythmie, RSA, hervorgerufenen Modulationen der Amplituden von mindestens drei Pulswellenformsignalen, mindestens drei PPI-Signalen und mindestens drei PTT-Signalen zu analysieren, um mindestens neun Atemfrequenz-, RR-, Metriken zu berechnen und diese mindestens neun RR-Metriken zu kombinieren, um einen RR-Parameter des Benutzers auszuwerten und anzugeben;

die mindestens drei arteriellen Pulswellenformsignale zu analysieren, um mindestens zwei Blutsauerstoffsättigungs-, SpO₂-, Metriken zu berechnen und die mindestens zwei Blutsauerstoffsättigungs-, SpO₂-, Metriken zu kombinieren, um einen SpO₂-Wert des Benutzers auszuwerten und anzugeben;

Daten des Beschleunigungsmessers zu analysieren, um den Aktivitätsgrad des Nutzers genau anzugeben; und optional Funktionen des globalen Positionierungssystems, GPS, zu nutzen, um den Standort des Benutzers genau anzugeben,

wobei der mindestens eine Parameter des Benutzers den mindestens einen NIBP-Parameter, den HR-Parameter und den RR-Parameter und/oder den SpO₂-Wert des Benutzers beinhaltet.

8. Intelligentes Armband (102) nach einem der Ansprüche 1 bis 7, weiter umfassend ein GPS-Modul (902), ein Speichermodul (904) und ein Touchscreen-Display (502), wobei die Mikrosteuereinheit (414) so konfiguriert ist, dass sie GPS-Daten über das GPS-Modul (902) erfasst und analysiert, um den Standort des Benutzers genau anzugeben, und wobei die Mikrosteuereinheit (414) optional so konfiguriert ist, dass sie Daten anzeigt, Daten speichert, Benutzereingaben über das Touchscreen-Display (502) empfängt und/oder Daten an eine oder mehrere andere externe Vorrichtungen (116) überträgt.

9. Intelligentes Armband (102) nach Anspruch 3, wobei die Mikrosteuereinheit (414) so konfiguriert ist, dass sie ein EKG-Wellenformsignal über die mindestens drei EKG-Elektroden (504, 702, 704) erfasst, sobald zwei der mindestens drei EKG-Elektroden die Haut des Benutzers auf einer Körperseite relativ zum Herzen des Benutzers berühren und eine der mindestens drei Elektroden auch die Haut des Benutzers auf der anderen Körperseite relativ zum Herzen des Benutzers berührt, und wobei die Mikrosteuereinheit (414) und/oder ein externe Vorrichtung (106, 116) so konfiguriert sind, dass sie das EKG-Wellenformsignal analysieren, um den mindestens einen Parameter des Benutzers anzugeben, wobei der mindestens eine Parameter die HR und eine Herzfrequenzvariabilität, HRV, des Benutzers beinhaltet.

10. Intelligentes Armband (102) nach einem der Ansprüche 1 bis 9, weiter umfassend eine Oberseite (202) und ein Band (312), wobei das Band (312) eine Dichtung (318) aufweist, die um die Rückplatte (206), die Oberseite (202), die Mikrosteuereinheit (414) und die Biosensoren abgedichtet ist, wobei das Band (312) optional aus einem elastischen Material besteht und als einteiliges Stück konfiguriert ist.

11. Intelligentes Armband (102) nach einem der Ansprüche 1 bis 10, wobei die Mikrosteuereinheit (414) konfiguriert ist, eine manuelle und/oder automatische intermittierende und/oder kontinuierliche physiologische Überwachung gemäß einer vom Benutzer festgelegten Überwachungsfrequenz durchzuführen, wobei die Mikrosteuereinheit (414) optional so konfiguriert ist, dass sie auf der Grundlage der aus den Daten der Biosensoren gewonnenen vielfältigen Vitalzeichen Gesundheitswarnungen generiert.

12. Intelligentes Armband (102) nach Anspruch 2, wobei die Rückplatte (206) Lichtbarrieren zwischen allen der mindestens drei LEDs (214) und allen des mindestens einen PD-Sensors (208) der mindestens drei PPG-Sensoren umfasst und weiter einzelne transparente Linsen zur optischen Isolierung und physikalischen Einkapselung jeder der mindestens drei LEDs (214) und des mindestens einen PD-Sensors (208) zur Verbesserung der Qualität der arteriellen Pulswellenformdaten sowie zum Schutz der Komponenten der mindestens drei LEDs (214) und des mindestens einen PD-Sensors (208) vor Staub, Feuchtigkeit und mechanischen Beschädigungen umfasst, wobei die Rückplatte (206) optional mittels eines industriellen Mehrkomponenten-Spitzgussverfahrens hergestellt und optional aus Acrylnitril-Butadien-Styrol, ABS, geformt ist, während jede der einzelnen transparenten Linsen optional aus transparenten Materialien geformt ist.

13. Intelligentes Armband (102) nach einem der Ansprüche 1 bis 12, wobei die Mikrosteuereinheit (414) so konfiguriert ist, dass sie mindestens drei arterielle Pulswellenformsignale über die mindestens drei PPG-Sensoren erfasst und eine automatische Verstärkungsregelung, AGC, nutzt, um die Qualität und Genauigkeit der drei arteriellen Pulswellen-

formsignale für alle Benutzer zu standardisieren, wobei die Verstärkung der drei arteriellen Pulswellenformsignale entweder automatisch von der Mikrosteuereinheit (414) gesteuert wird oder manuell vom Benutzer durch Verändern von Schieberegler auf einer Benutzerschnittstelle, UI, gesteuert wird, die mit der Mikrosteuereinheit (414) in Kommunikation steht.

- 5
14. Intelligentes Armband (102) nach einem der Ansprüche 1 bis 13, das weiter Elektrokardiogramm-, EKG-, Elektroden umfasst, wobei die Mikrosteuereinheit (414) so konfiguriert ist, dass sie eine automatische Verstärkungsregelung, AGC, nutzt, um die Qualität und Genauigkeit des EKG-Signals von den EKG-Elektroden für alle Benutzer des intelligenten Armbands (102) zu standardisieren, wobei die Verstärkung des EKG-Signals entweder automatisch von der Mikrosteuereinheit (414) oder manuell vom Benutzer durch Verändern eines Schiebereglers auf einer Benutzeroberfläche gesteuert wird.
- 10
15. Intelligentes Armband (102) nach Anspruch 2, wobei die Mikrosteuereinheit (414) so konfiguriert ist, dass sie die Pulsweitenmodulations-, PWM-, Technik nutzt, um die mindestens drei LEDs (214) der mindestens drei PPG-Sensoren zu steuern und synchron Daten von dem mindestens einen PD-Sensor (208) auszulesen, um Interferenzen zwischen nicht verbundenen LEDs und PDs zu minimieren und ein Überhitzen der LEDs (214) zu verhindern.
- 15
16. Intelligentes Armband (102) nach einem der Ansprüche 1 bis 15, weiter umfassend einen Beschleunigungssensor (416), wobei die Mikrosteuereinheit (414) über den Beschleunigungssensor (416) Daten zur Benutzeraktivität erfasst;
- 20
- wobei die Mikrosteuereinheit (414) so konfiguriert ist, dass sie die mindestens drei arteriellen Pulswellenformsignale über die mindestens drei PPG-Sensoren erfasst, und wobei die Mikrosteuereinheit (414) synchron erfasste Daten des Beschleunigungssensors (416) verwendet, um Rauschen aus den mindestens drei arteriellen Pulswellenformsignalen zu entfernen und so die Genauigkeit einer Auswertung mindestens eines Parameters weiter zu erhöhen, wobei der mindestens eine Parameter eine Herzfrequenz, HR, eine Herzfrequenzvariabilität, HRV, eine Atemfrequenz, RR, eine Blutsauerstoffsättigung, SpO₂ und/oder eine nicht-invasive Blutdruckmessung, NIBP, des Benutzers beinhaltet.
- 25
17. Intelligentes Armband (102) nach einem der Ansprüche 1 bis 16, wobei die Mikrosteuereinheit (414) so konfiguriert ist, dass sie ein EKG-Wellenformsignal über die mindestens drei EKG-Elektroden erfasst, und wobei die Mikrosteuereinheit (414) synchron erfasste Daten eines Beschleunigungssensors (416) verwendet, um Rauschen aus dem EKG-Wellenformsignal zu entfernen und so die Genauigkeit einer Auswertung des mindestens einen Parameters weiter zu erhöhen, wobei der mindestens eine Parameter eine Herzfrequenz, HR, eine Herzfrequenzvariabilität, HRV, und eine Atemfrequenz, RR, des Benutzers beinhaltet.
- 30
18. Intelligentes Armband (102) nach einem der Ansprüche 1 bis 17, wobei die von der externen Vorrichtung (106, 116) empfangenen Daten von einer auf der externen Vorrichtung (106, 116) laufenden Softwareanwendung analysiert werden, um Parameter wie NIBP, SpO₂, HR, RR, Temperatur, Standort, Aktivität, PTT und PWV anzugeben.
- 35

40

Revendications

1. Bracelet intelligent (102) pour la surveillance physiologique multiparamètre comprenant :

45

une plaque arrière (206) ;
 plusieurs biocapteurs incluant au moins trois capteurs de photopléthysmographie, PPG, configurés pour entrer en contact avec la peau d'un utilisateur à au moins trois emplacements distincts (208, 212, 216) ; et
 un microcontrôleur (414) en communication avec les biocapteurs et configuré pour déterminer plusieurs signes vitaux à partir de données provenant des biocapteurs, dans lequel le microcontrôleur (414) est configuré pour recevoir au moins trois signaux de forme d'onde de pouls artériel par l'intermédiaire des au moins trois capteurs de PPG ; et
 un émetteur-récepteur (418) configuré pour la communication sans fil, dans lequel le microcontrôleur (414) est configuré pour utiliser l'émetteur-récepteur (418) afin d'envoyer les signes vitaux ou les données à un dispositif externe (106, 116) ;
 dans lequel les au moins trois capteurs de PPG sont situés sur toute une longueur de la plaque arrière (206), séparés les uns des autres par des distances prédéterminées, et configurés collectivement pour mesurer les au moins trois signaux de forme d'onde de pouls artériel, chacun avec différents temps d'arrivée d'impulsion, à partir des au moins trois emplacements distincts (208, 212, 216) sur la peau de l'utilisateur, permettant la mesure d'au

50

55

EP 4 114 252 B1

moins trois signaux de temps de transit d'impulsion, PTT, et dans lequel le microcontrôleur (414) est configuré pour calculer au moins trois mesures de PTT en utilisant les différents temps d'arrivée d'impulsion et les distances prédéterminées, et pour utiliser ensuite les au moins trois mesures de PTT pour calculer au moins un paramètre de l'utilisateur ; et

dans lequel le dispositif externe (106, 116) et/ou le microcontrôleur (414) sont configurés pour détecter et corriger automatiquement une mauvaise fixation du bracelet intelligent (102) sur un membre (104) de l'utilisateur par l'intermédiaire de l'identification de temps de transit d'impulsion négatifs dans les au moins trois signaux de PTT obtenus à partir des au moins trois capteurs de PPG, et si les temps de transit négatifs sont identifiés, fournir une alerte de mauvaise fixation et/ou corriger les temps de transit d'impulsion négatifs en multipliant les temps de transmission d'impulsion négatifs dans les au moins trois signaux de PTT par -1.

2. Bracelet intelligent (102) selon la revendication 1, dans lequel chacun des au moins trois capteurs de PPG respectifs inclut au moins trois diodes électroluminescentes, LED (214), et au moins un capteur de à photodiode, PD (208), et dans lequel les biocapteurs comprennent en outre, facultativement, un capteur de température (220), dans lequel des données de capteur de température (220) sont facultativement agrégées pour signaler une température corporelle.

3. Bracelet intelligent (102) selon la revendication 1 ou 2, comprenant en outre une face supérieure (202), dans lequel les biocapteurs comprennent en outre au moins trois électrodes d'ECG (504, 702, 704), dans lequel deux électrodes d'ECG (702, 704) sont dans la plaque arrière (206), tandis qu'une électrode d'ECG (504) est dans la face supérieure (202), et dans lequel l'une des deux électrodes d'ECG dans la plaque arrière (206) est facultativement une électrode active.

4. Bracelet intelligent (102) selon l'une quelconque des revendications 1 à 3, dans lequel les biocapteurs mesurent les signes vitaux et les signes vitaux incluent la fréquence cardiaque, HR, la variabilité de la fréquence cardiaque, HRV, la saturation en oxygène du sang, SpO₂, la pression artérielle non invasive, NIBP, la fréquence respiratoire, RR, la température du corps et le pouls artériel, ainsi que la surveillance de l'électrocardiogramme, ECG.

5. Bracelet intelligent (102) selon l'une quelconque des revendications 1 à 4, dans lequel le microcontrôleur est configuré pour utiliser l'émetteur-récepteur pour envoyer les signes vitaux ou les données brutes en temps réel à un ou plusieurs dispositifs externes (106), et dans lequel les un ou plusieurs dispositifs externes (106) sont configurés pour afficher des données, stocker des données et/ou transmettre des données à d'autres dispositifs externes (116).

6. Bracelet intelligent (102) selon l'une quelconque des revendications 1 à 5, comprenant en outre un capteur d'accéléromètre (416), dans lequel le microcontrôleur (414) obtient des données d'activité utilisateur et/ou des données de mouvement par l'intermédiaire du capteur d'accéléromètre (416).

7. Bracelet intelligent (102) selon l'une quelconque des revendications 1 à 6, dans lequel le microcontrôleur (414) et/ou dispositif externe (106, 116) sont configurés pour obtenir au moins trois signaux de forme d'onde de pouls artériel par l'intermédiaire des au moins trois capteurs de PPG, et dans lequel le microcontrôleur (414) et/ou le dispositif externe (106, 116) sont configurés pour

analyser les au moins trois signaux de forme d'onde de pouls artériel pour calculer au moins trois temps de transit d'impulsion, PTT, au moins trois vitesses d'onde de pouls, PWV, et au moins trois mesures d'amplitude de pouls, et combiner les au moins trois PTT, les au moins trois PWV et les au moins trois mesures d'amplitude de pouls afin d'évaluer et de signaler au moins un paramètre de pression artérielle non invasive, NIBP, de l'utilisateur ;

analyser les au moins trois signaux de forme d'onde de pouls artériel pour calculer au moins trois mesures d'intervalle crête à crête, PPI, et combiner les au moins trois mesures de PPI afin d'évaluer et de signaler un paramètre de fréquence cardiaque, HR, de l'utilisateur ;

analyser l'arythmie sinusale respiratoire, RSA, des modulations induites dans des amplitudes des au moins trois signaux de forme d'onde de pouls, des au moins trois signaux de PPI et des au moins trois signaux de PTT pour calculer au moins neuf mesures de fréquence respiratoire, RR, et combiner les au moins neuf mesures de RR afin d'évaluer et de signaler un paramètre de RR de l'utilisateur ;

analyser les au moins trois signaux de forme d'onde de pouls artériel pour calculer au moins deux mesures de saturation en oxygène du sang, SpO₂, et combiner les au moins deux mesures de SpO₂ afin d'évaluer et de signaler un taux de SpO₂ de l'utilisateur ;

analyser des données d'accéléromètre pour signaler avec précision le niveau d'activité de l'utilisateur ; et facultativement utiliser des capacités de système mondial de positionnement, GPS, pour signaler avec précision une position de l'utilisateur,

EP 4 114 252 B1

dans lequel le au moins un paramètre de l'utilisateur inclut le au moins un paramètre de NIBP, le paramètre de HR, le paramètre de RR et/ou le taux de SpO₂ de l'utilisateur.

- 5 8. Bracelet intelligent (102) selon l'une quelconque des revendications 1 à 7, comprenant en outre un module de GPS (902), un module de mémoire (904) et un écran tactile (502), dans lequel le microcontrôleur (414) est configuré pour obtenir des données GPS par l'intermédiaire du module de GPS (902) et analyser les données GPS pour signaler avec précision une position de l'utilisateur, et dans lequel le microcontrôleur (414) est configuré facultativement pour afficher des données, stocker des données et recevoir des entrées utilisateur par l'intermédiaire de l'écran tactile (502) et/ou transmettre des données à un ou plusieurs autres dispositifs externes (116).
10
9. Bracelet intelligent (102) selon la revendication 3, dans lequel le microcontrôleur (414) est configuré pour obtenir un signal de forme d'onde d'ECG par l'intermédiaire des au moins trois électrodes d'ECG (504, 702, 704) dès que deux des au moins trois électrodes d'ECG entrent en contact avec la peau de l'utilisateur d'un côté du corps par rapport au cœur de l'utilisateur et l'une des au moins trois électrodes entre, également, en contact avec la peau de l'utilisateur de l'autre côté du corps par rapport au cœur de l'utilisateur, et dans lequel le microcontrôleur (414) et/ou un dispositif externe (106, 116) sont configurés pour analyser le signal de forme d'onde d'ECG pour signaler le au moins un paramètre de l'utilisateur, le au moins un paramètre incluant la HR et une variabilité de HR, HRV, de l'utilisateur.
15
10. Bracelet intelligent (102) selon l'une quelconque des revendications 1 à 9, comprenant en outre une face supérieure (202) et une sangle (312), dans lequel la sangle (312) inclut un joint (318) qui est scellé autour de la plaque arrière (206), de la face supérieure (202), du microcontrôleur (414) et des biocapteurs, dans lequel la sangle (312) est facultativement constituée d'un matériau élastomère et configurée comme une seule pièce.
20
11. Bracelet intelligent (102) selon l'une quelconque des revendications 1 à 10, dans lequel le microcontrôleur (414) est configuré pour réaliser une surveillance physiologique intermittente manuelle et/ou automatique et/ou continue selon une fréquence de surveillance précisée par l'utilisateur et dans lequel le microcontrôleur (414) est configuré facultativement pour générer des alertes de santé sur la base de plusieurs signes vitaux obtenus à partir des données des biocapteurs.
25
12. Bracelet intelligent (102) selon la revendication 2, dans lequel la plaque arrière (206) comprend des barrières lumineuses entre toutes parmi les au moins trois LED (214) et toutes parmi le au moins un capteur de PD (208) des au moins trois capteurs de PPG, et comprend en outre des lentilles transparentes individuelles pour isoler optiquement et encapsuler physiquement chacune des au moins trois LED (214) et du au moins un capteur de PD (208) pour améliorer la qualité des données de forme d'onde de pouls artériel et pour protéger les composants des au moins trois LED (214) et du au moins un capteur de PD (208) contre la poussière, l'humidité et les dommages mécaniques, dans lequel la plaque arrière (206) est fabriquée facultativement en utilisant un procédé de co-moulage industriel et formée facultativement d'acrylonitrile butadiène styrène, ABS, tandis que chacune des lentilles transparentes individuelles est moulée facultativement en utilisant des matériaux transparents.
30
35
13. Bracelet intelligent (102) selon l'une quelconque des revendications 1 à 12, dans lequel le microcontrôleur (414) est configuré pour obtenir au moins trois signaux de forme d'onde de pouls artériel par l'intermédiaire des au moins trois capteurs de PPG et utiliser une commande automatique de gain, AGC, pour normaliser la qualité et la fidélité des trois signaux de forme d'onde de pouls artériel pour tous les utilisateurs, dans lequel des gains des trois signaux de forme d'onde de pouls artériel sont commandés automatiquement par le microcontrôleur (414), ou les gains sont commandés manuellement par l'utilisateur en faisant varier des curseurs sur une interface utilisateur, UI, qui sont en communication avec le microcontrôleur (414).
40
45
14. Bracelet intelligent (102) selon l'une quelconque des revendications 1 à 13, comprenant en outre des électrodes d'électrocardiogramme, ECG, dans lequel le microcontrôleur (414) est configuré pour utiliser des circuits de commande automatique de gain, AGC, pour normaliser la qualité et la fidélité d'un signal d'ECG à partir des électrodes d'ECG pour tous les utilisateurs du bracelet intelligent (102), dans lequel le gain du signal d'ECG est commandé automatiquement par le microcontrôleur (414) ou le gain est commandé manuellement par l'utilisateur en faisant varier un curseur sur une interface utilisateur.
50
15. Bracelet intelligent (102) selon la revendication 2, dans lequel le microcontrôleur (414) est configuré pour utiliser la technique de modulation de largeur d'impulsion, PWM, pour commander les au moins trois LED (214) des au moins trois capteurs de PPG et lire de manière synchrone des données à partir du au moins un capteur de PD (208) pour minimiser les interférences entre les LED et PD non associés et pour empêcher les LED (214) de chauffer.
55

EP 4 114 252 B1

16. Bracelet intelligent (102) selon l'une quelconque des revendications 1 à 15, comprenant en outre un capteur d'accéléromètre (416), dans lequel le microcontrôleur (414) obtient des données d'activité utilisateur par l'intermédiaire du capteur d'accéléromètre (416) ;
dans lequel le microcontrôleur (414) est configuré pour obtenir les au moins trois signaux de forme d'onde de pouls artériel par l'intermédiaire des au moins trois capteurs de PPG, et dans lequel le microcontrôleur (414) utilise des données collectées de manière synchrone à partir du capteur d'accéléromètre (416) pour retirer le bruit des au moins trois signaux de forme d'onde de pouls artériel afin d'améliorer en outre la précision de l'évaluation d'au moins un paramètre, le au moins un paramètre incluant une fréquence cardiaque, HR, une variabilité de la fréquence cardiaque, HRV, une fréquence respiratoire, RR, et un taux de saturation en oxygène du sang, SpO2 et/ou une pression artérielle non invasive, NIBP, de l'utilisateur.
17. Bracelet intelligent (102) selon l'une quelconque des revendications 1 à 16, dans lequel le microcontrôleur (414) est configuré pour obtenir un signal de forme d'onde d'ECG par l'intermédiaire des au moins trois électrodes d'ECG, et dans lequel le microcontrôleur (414) utilise des données collectées de manière synchrone à partir d'un capteur d'accéléromètre (416) pour retirer le bruit du signal de forme d'onde d'ECG afin d'améliorer en outre la précision de l'évaluation du au moins un paramètre, le au moins un paramètre incluant une fréquence cardiaque, HR, et une variabilité de la fréquence cardiaque, HRV, et/ou une fréquence respiratoire, RR, de l'utilisateur.
18. Bracelet intelligent (102) selon l'une quelconque des revendications 1 à 17, dans lequel les données reçues par le dispositif externe (106, 116) sont analysées par une application logicielle exécutée sur le dispositif externe (106, 116) pour signaler des paramètres, tels que NIBP, SpO₂, HR, RR, température, position, activité, PTT et PWV.

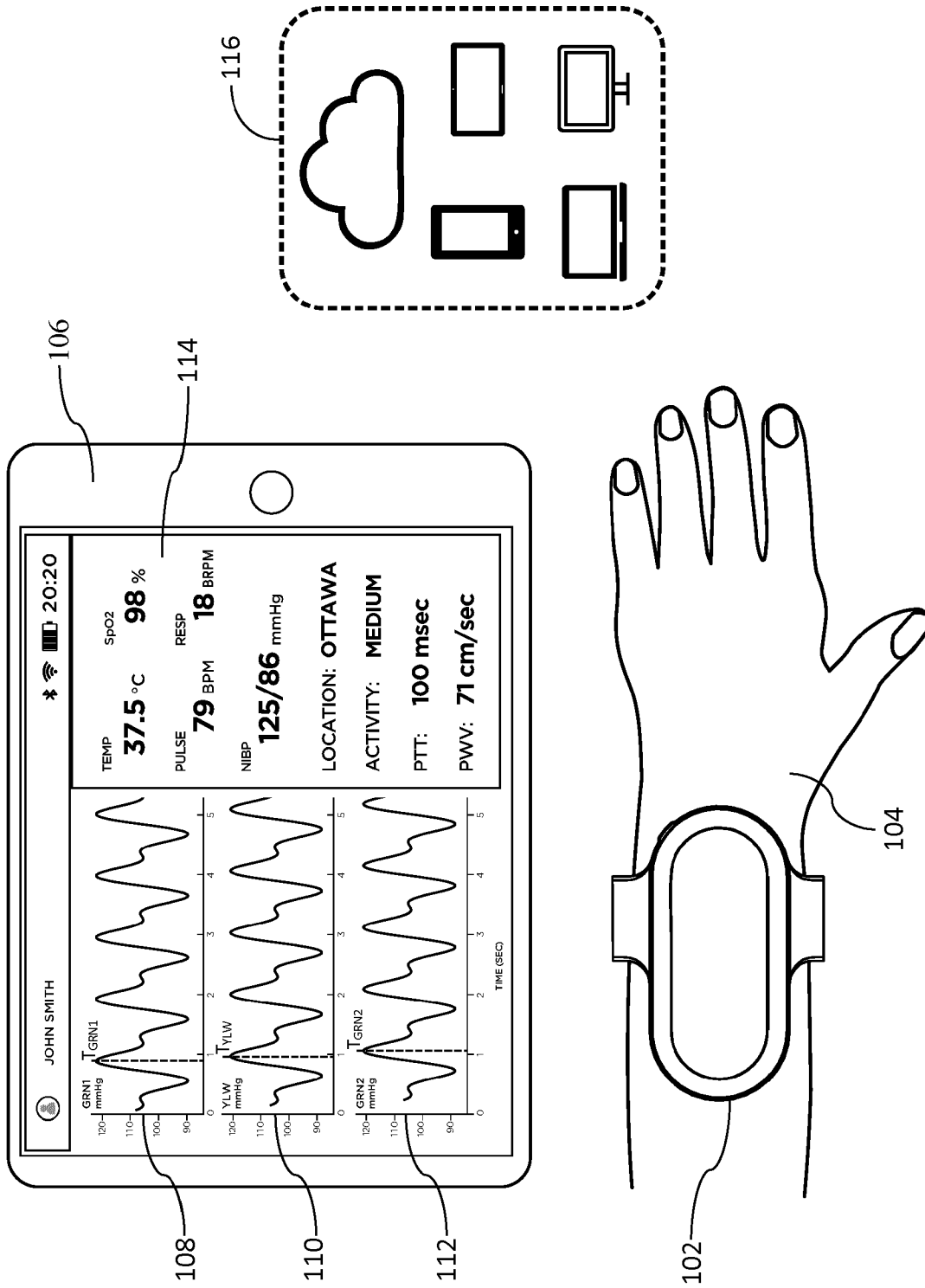

FIG. 1

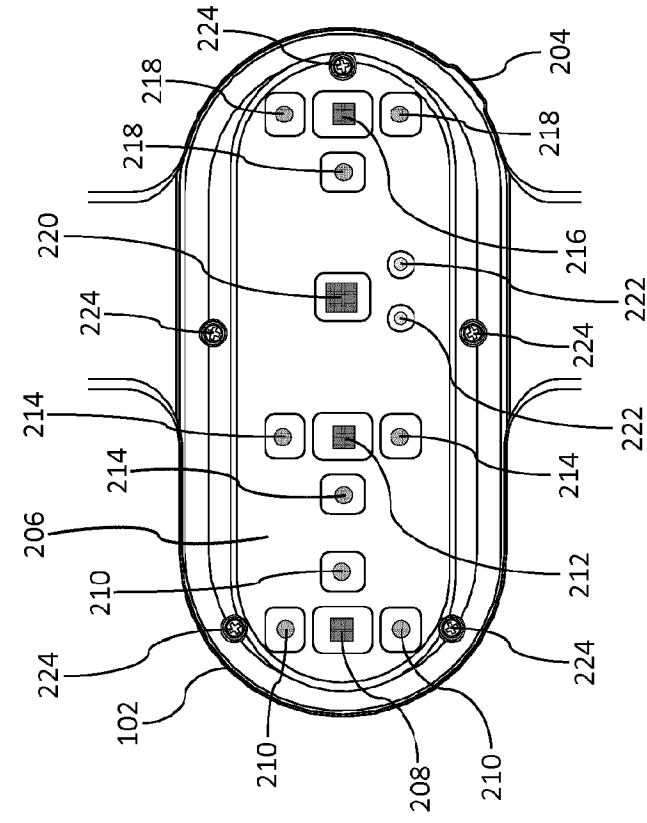

FIG. 2A

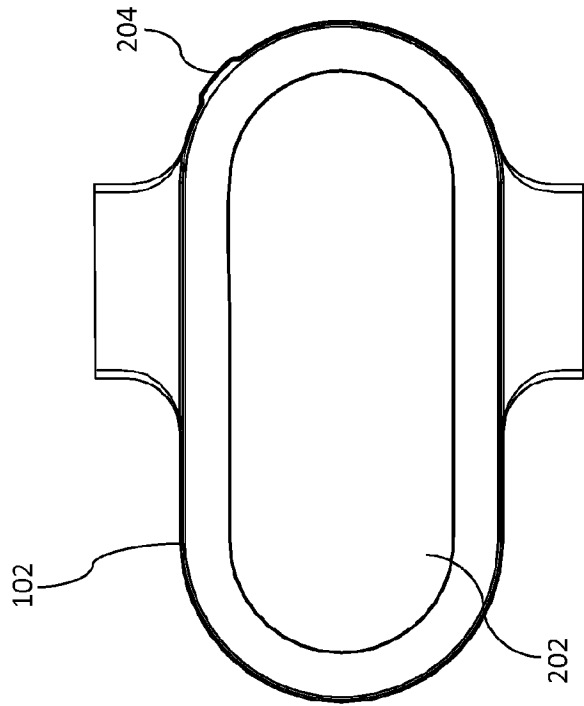

FIG. 2B

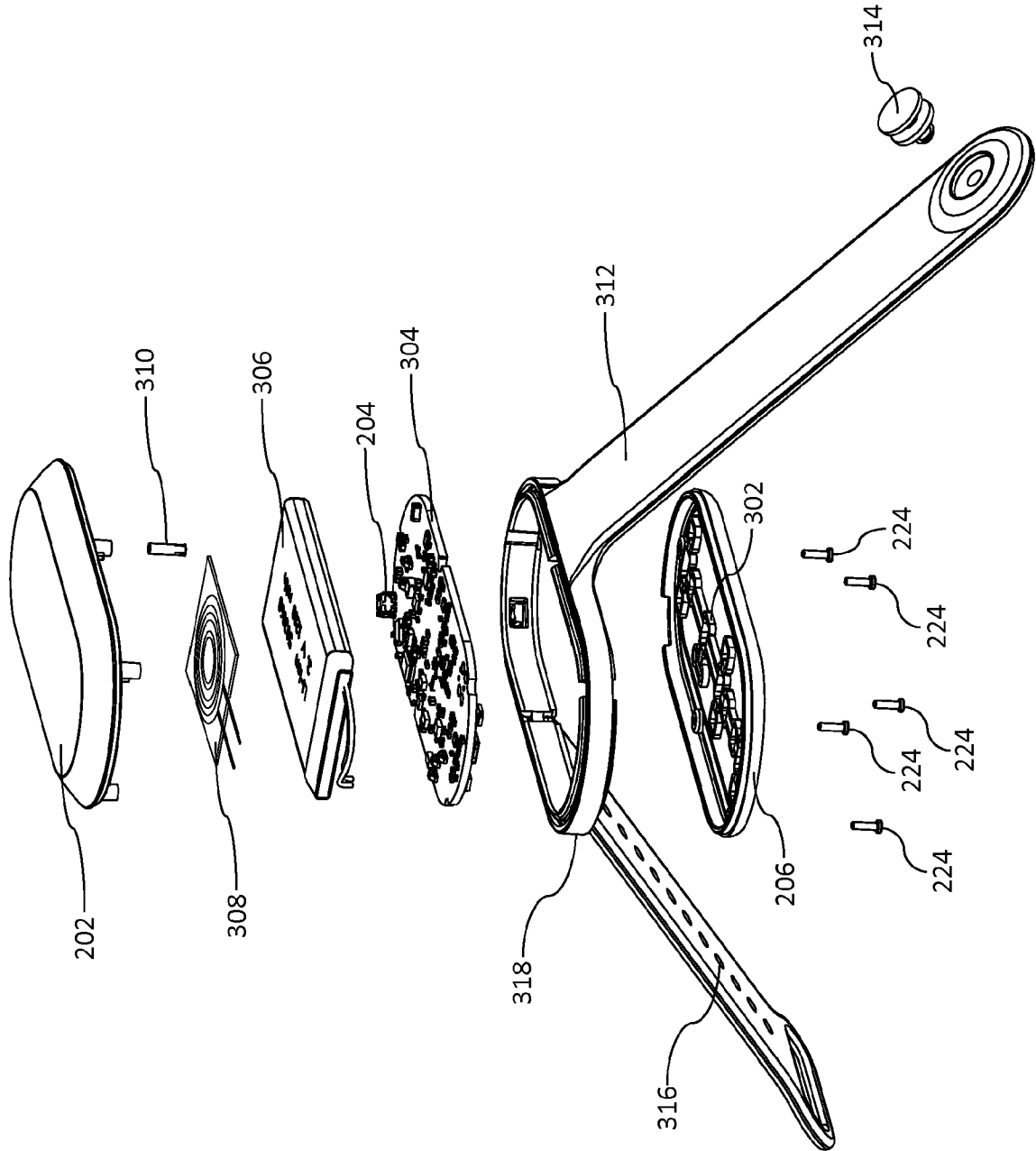

FIG. 3

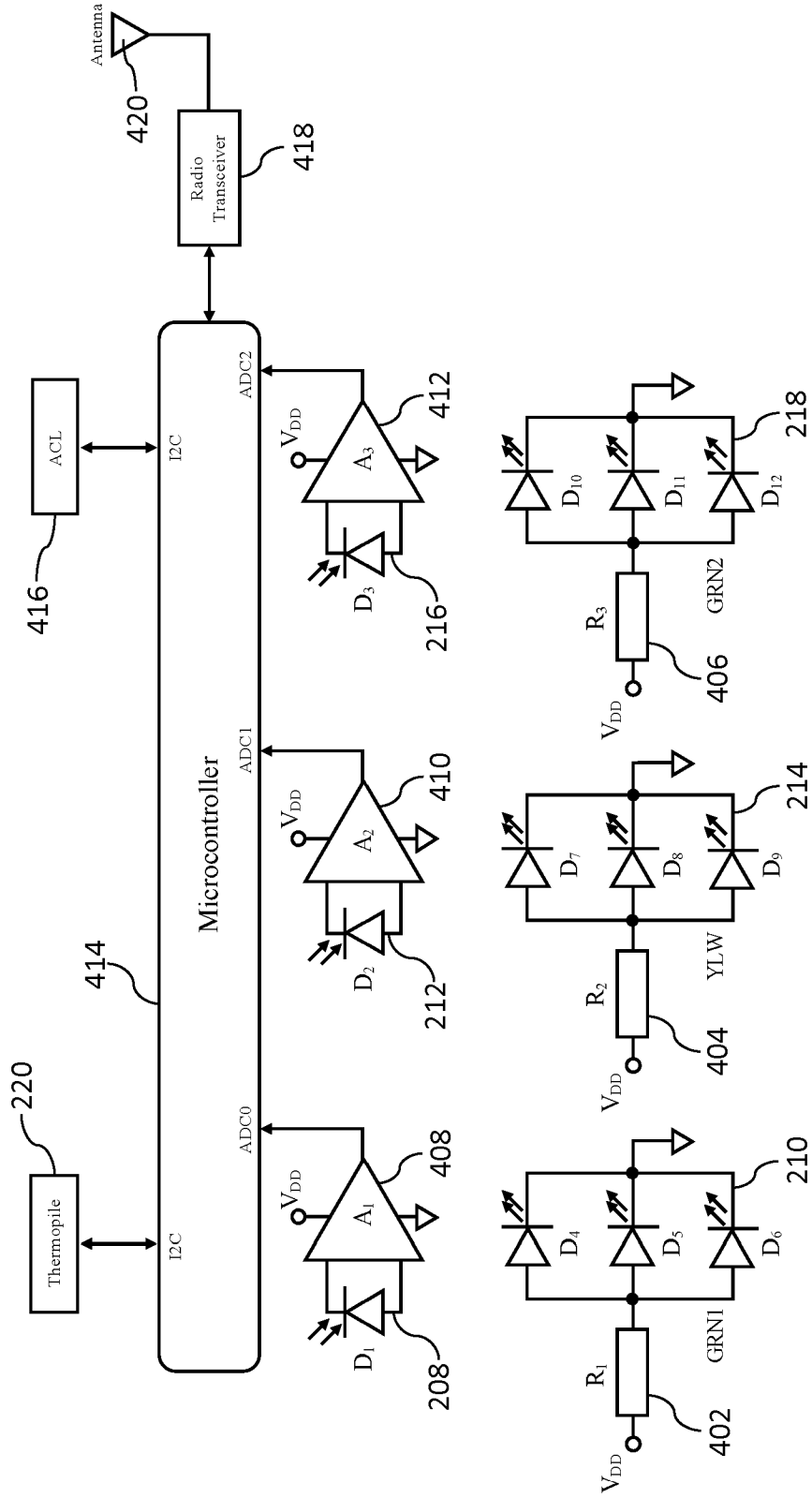

FIG. 4

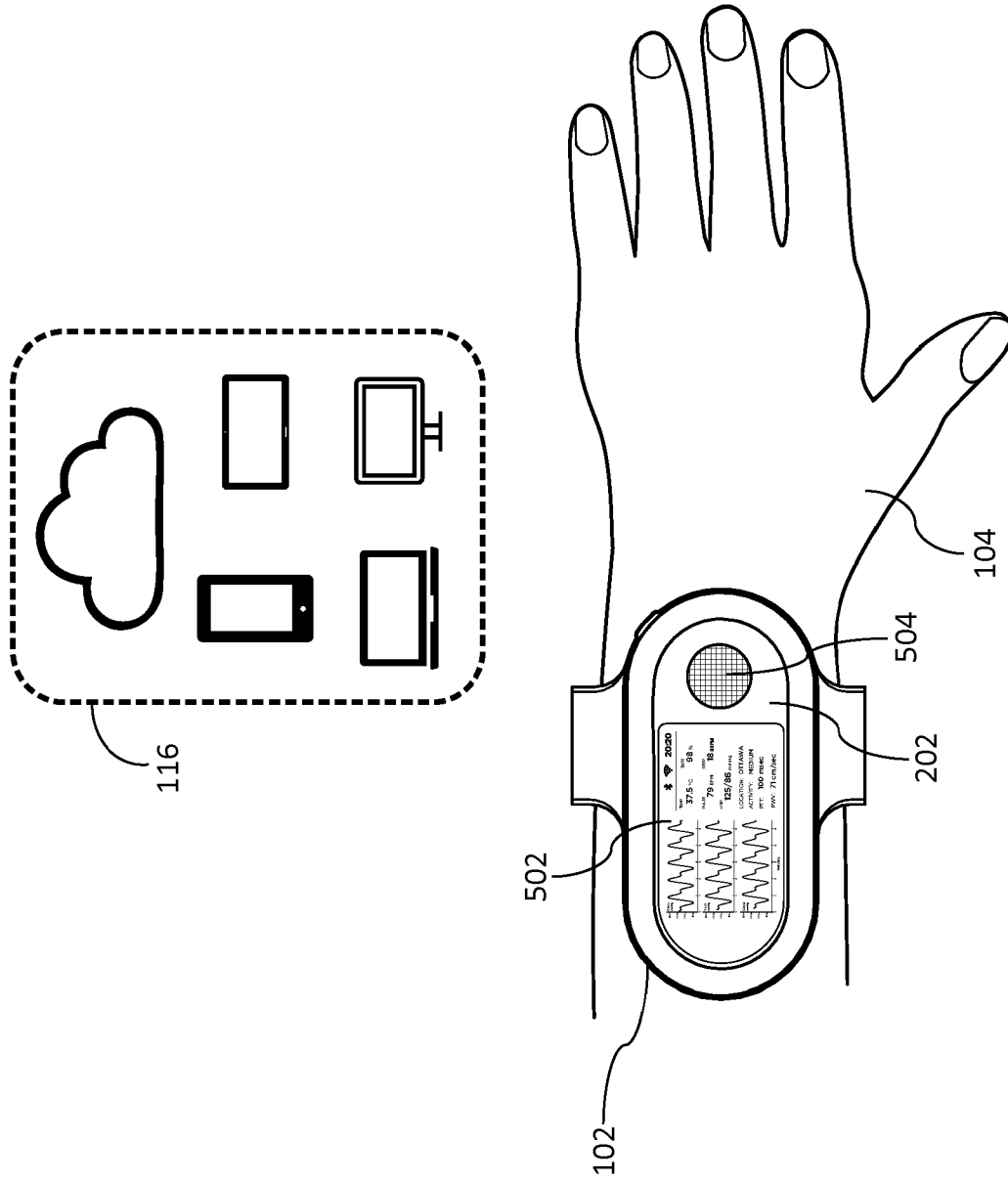

FIG. 5

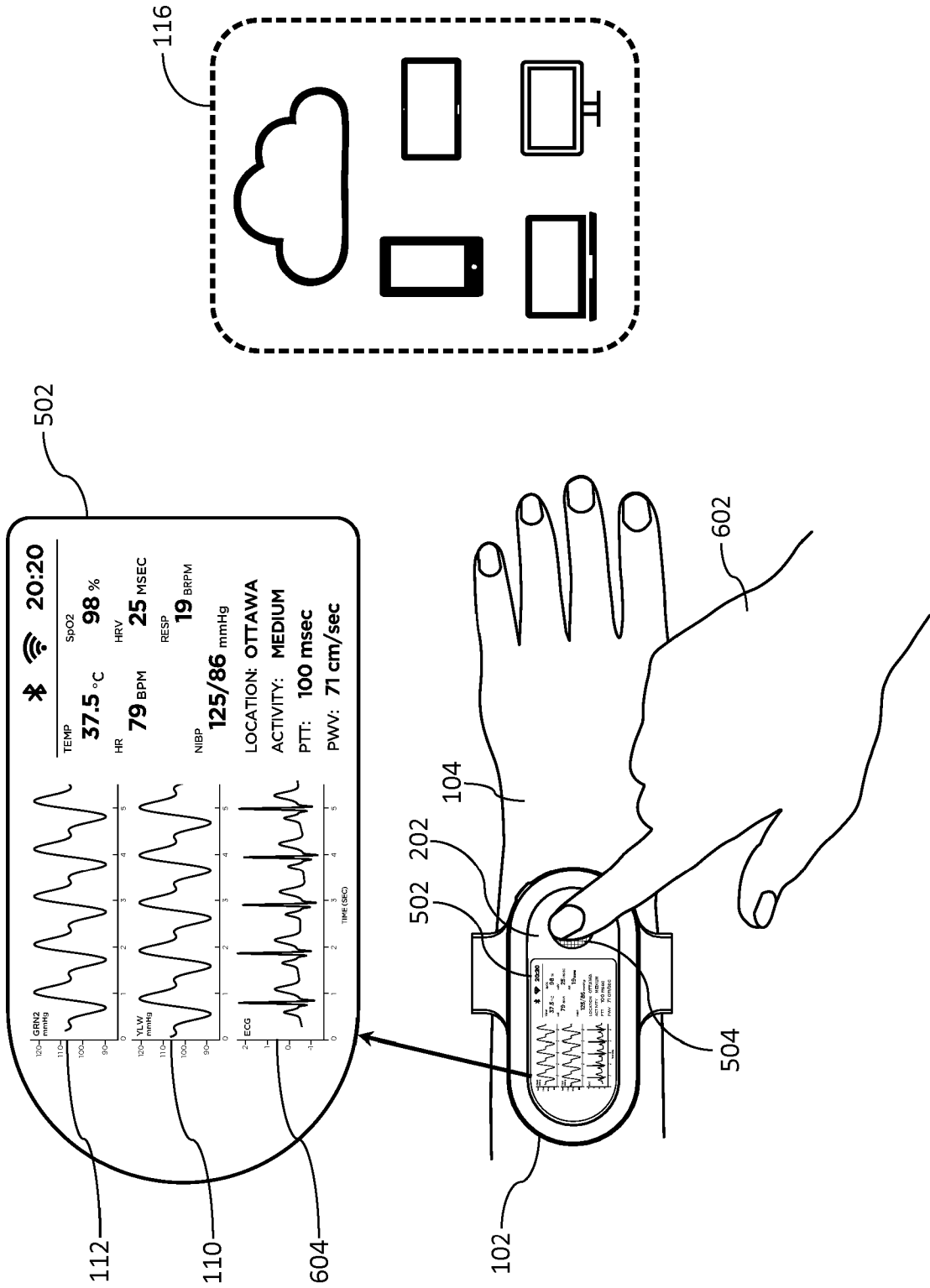

FIG. 6

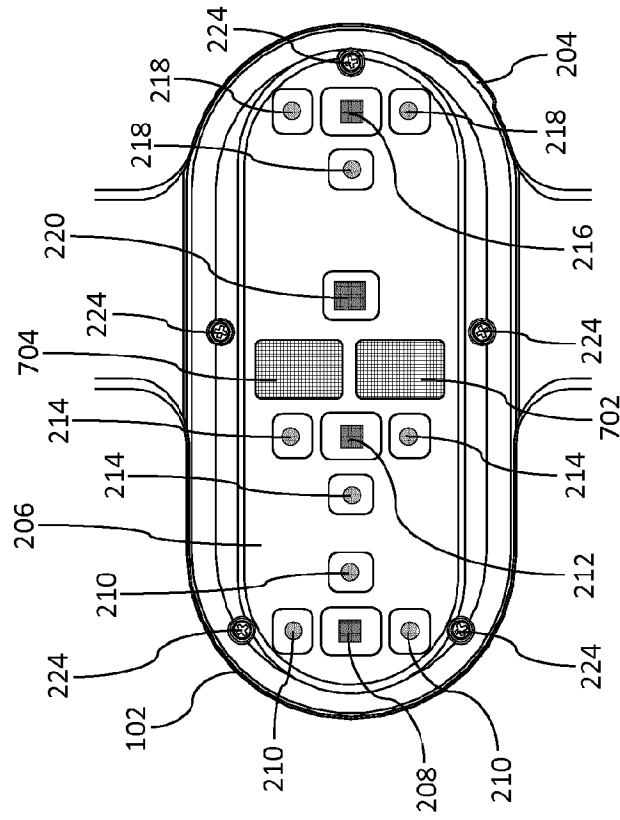

FIG. 7A

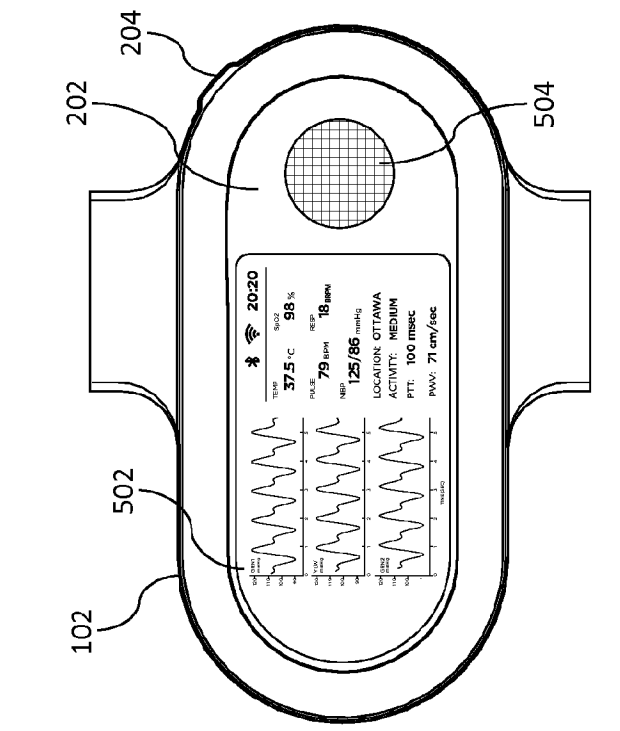

FIG. 7B

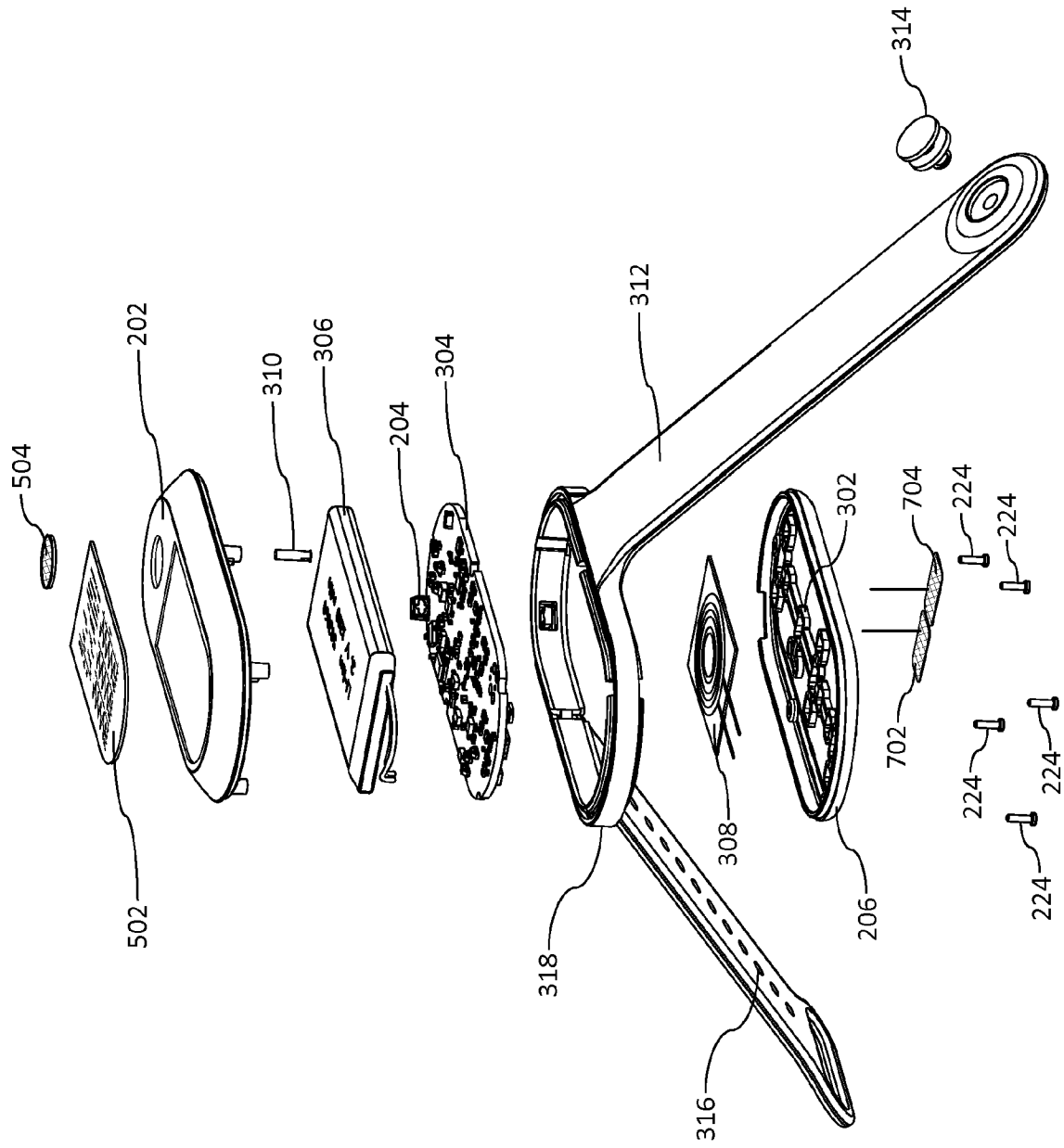

FIG. 8

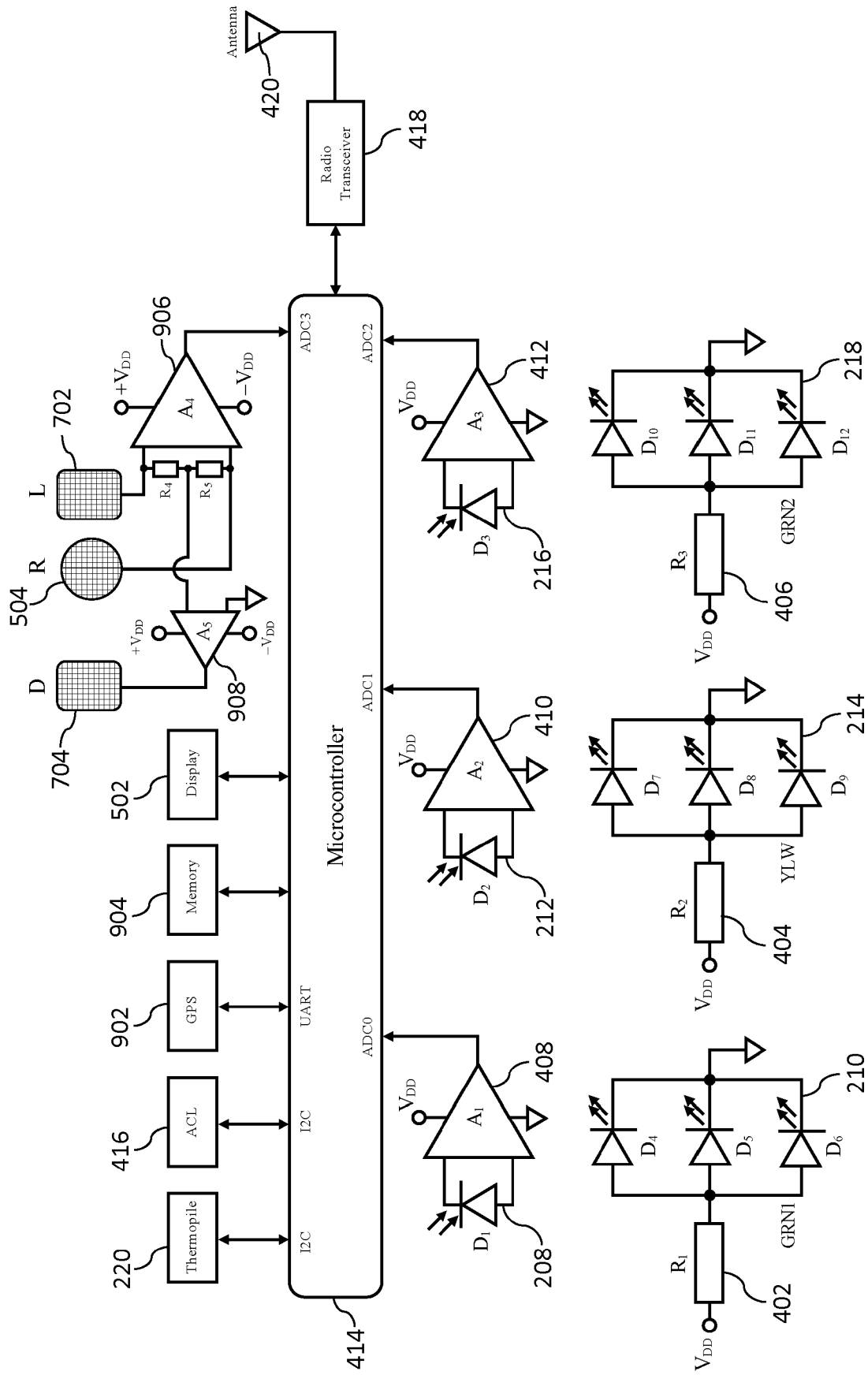

FIG. 9

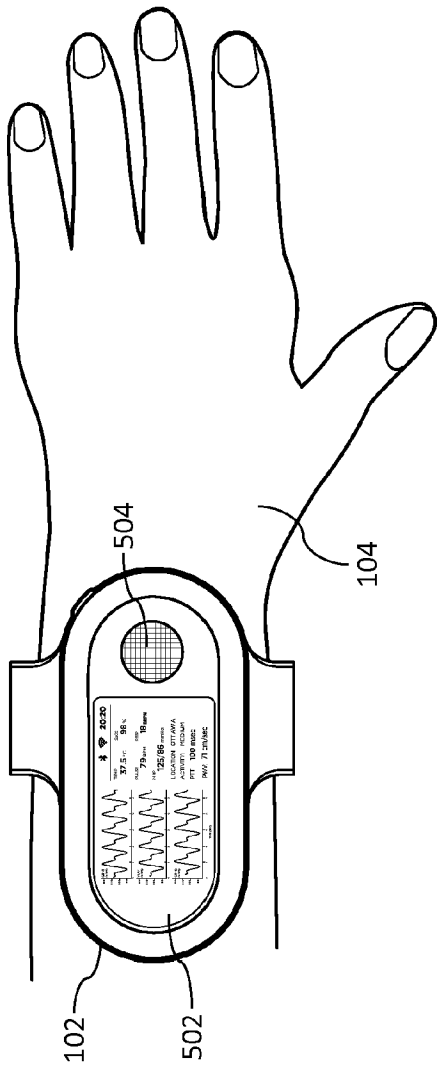

FIG. 10A

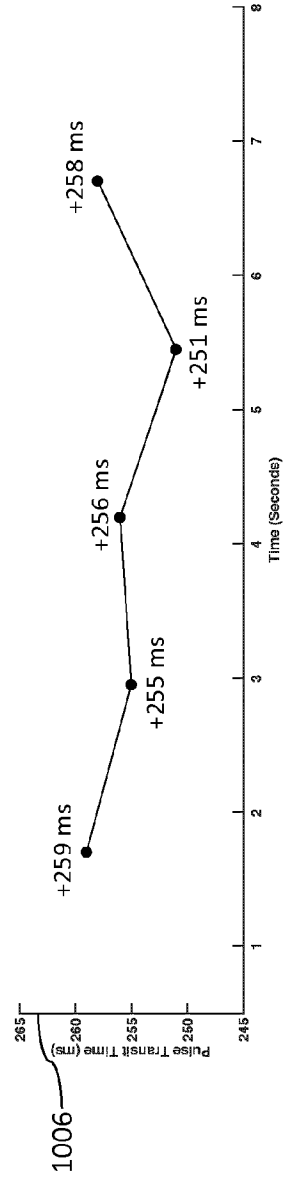
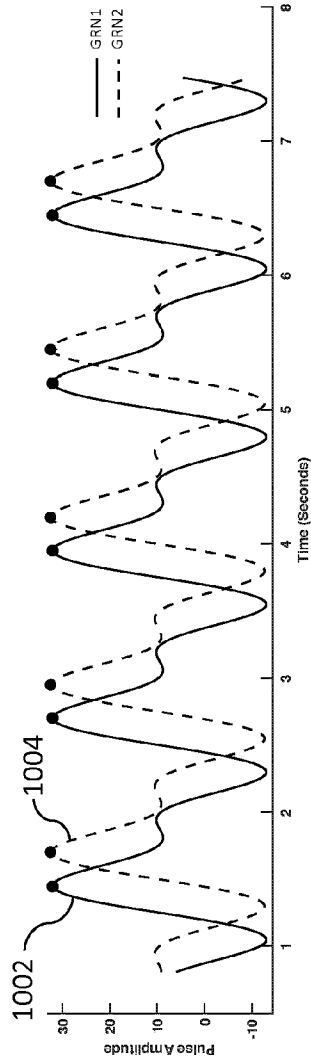

FIG. 10B

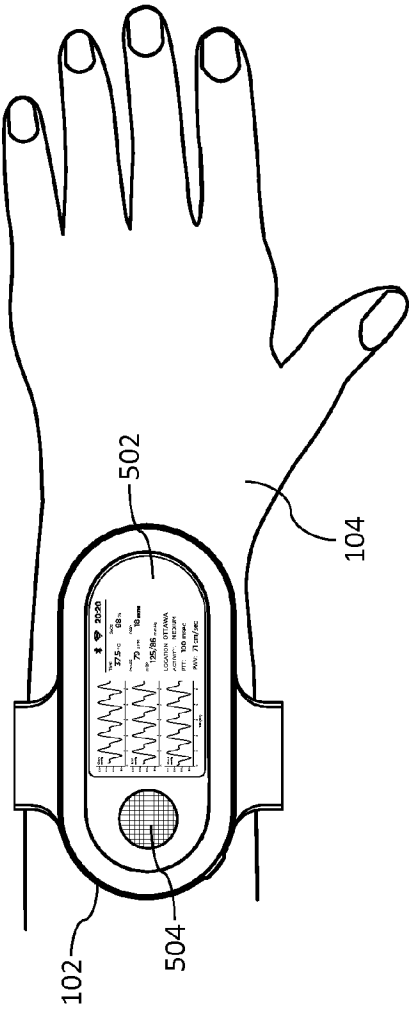

FIG. 11A

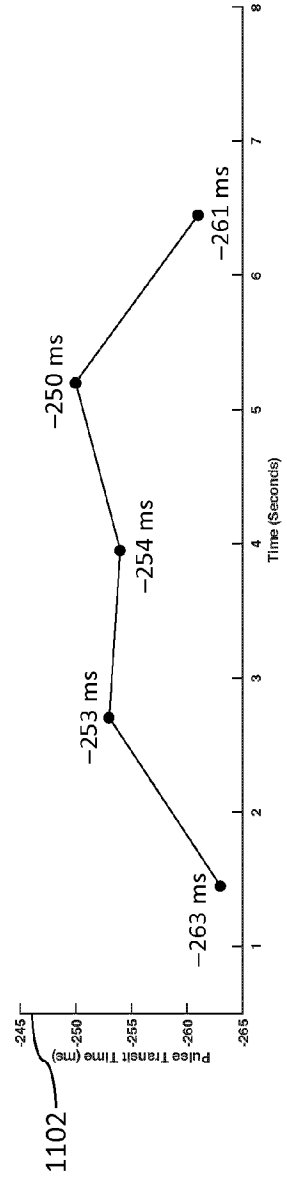
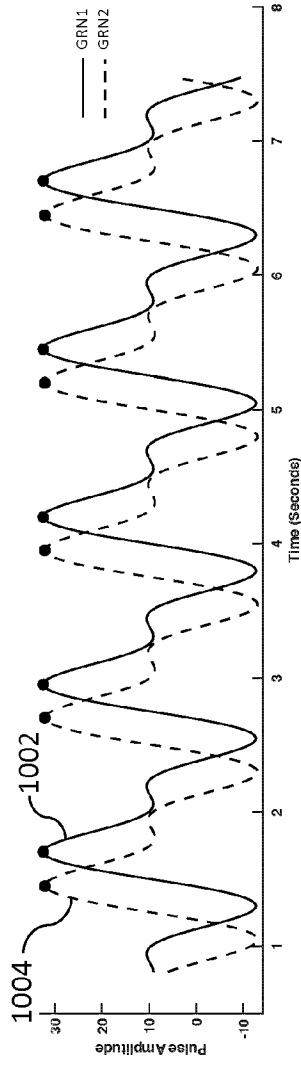

FIG. 11B

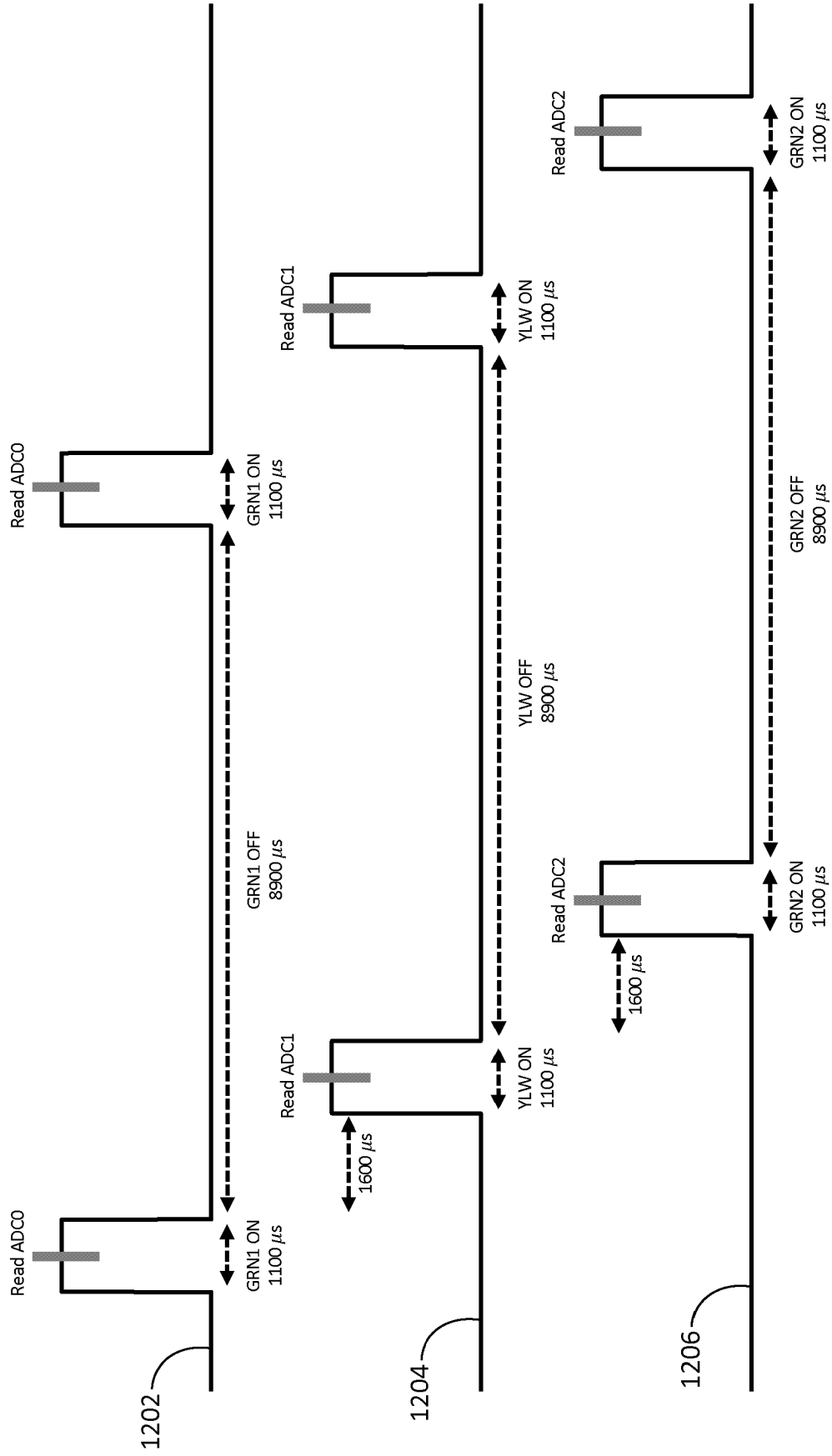

FIG. 12

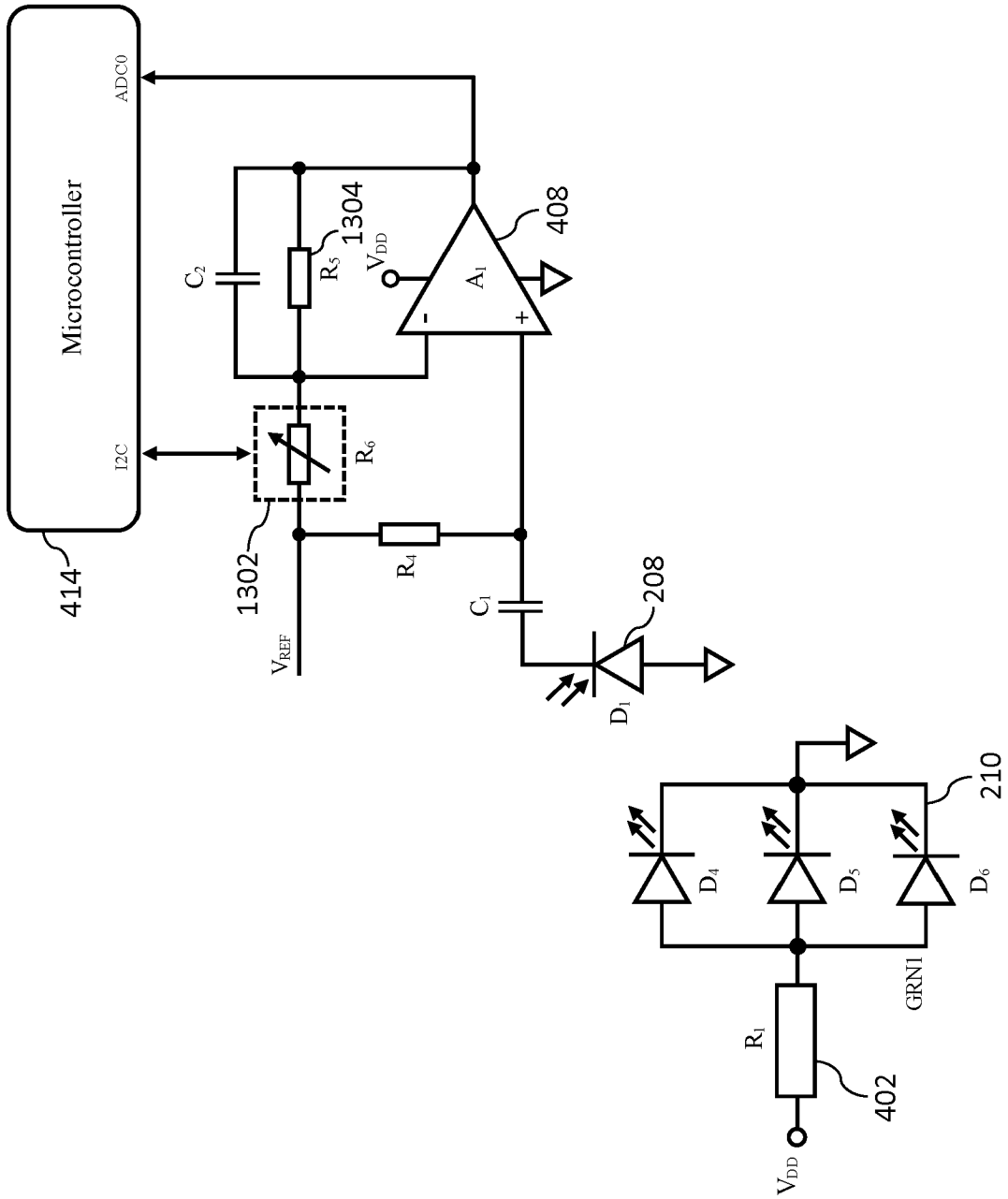

FIG. 13

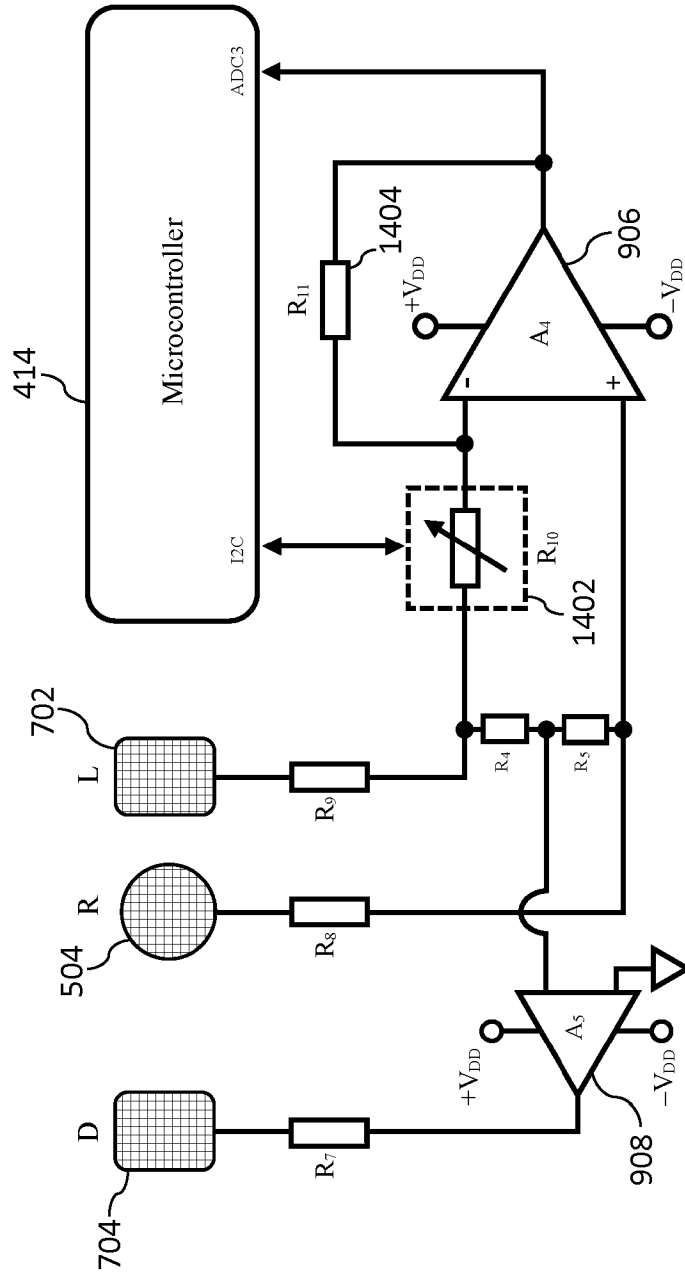

FIG. 14

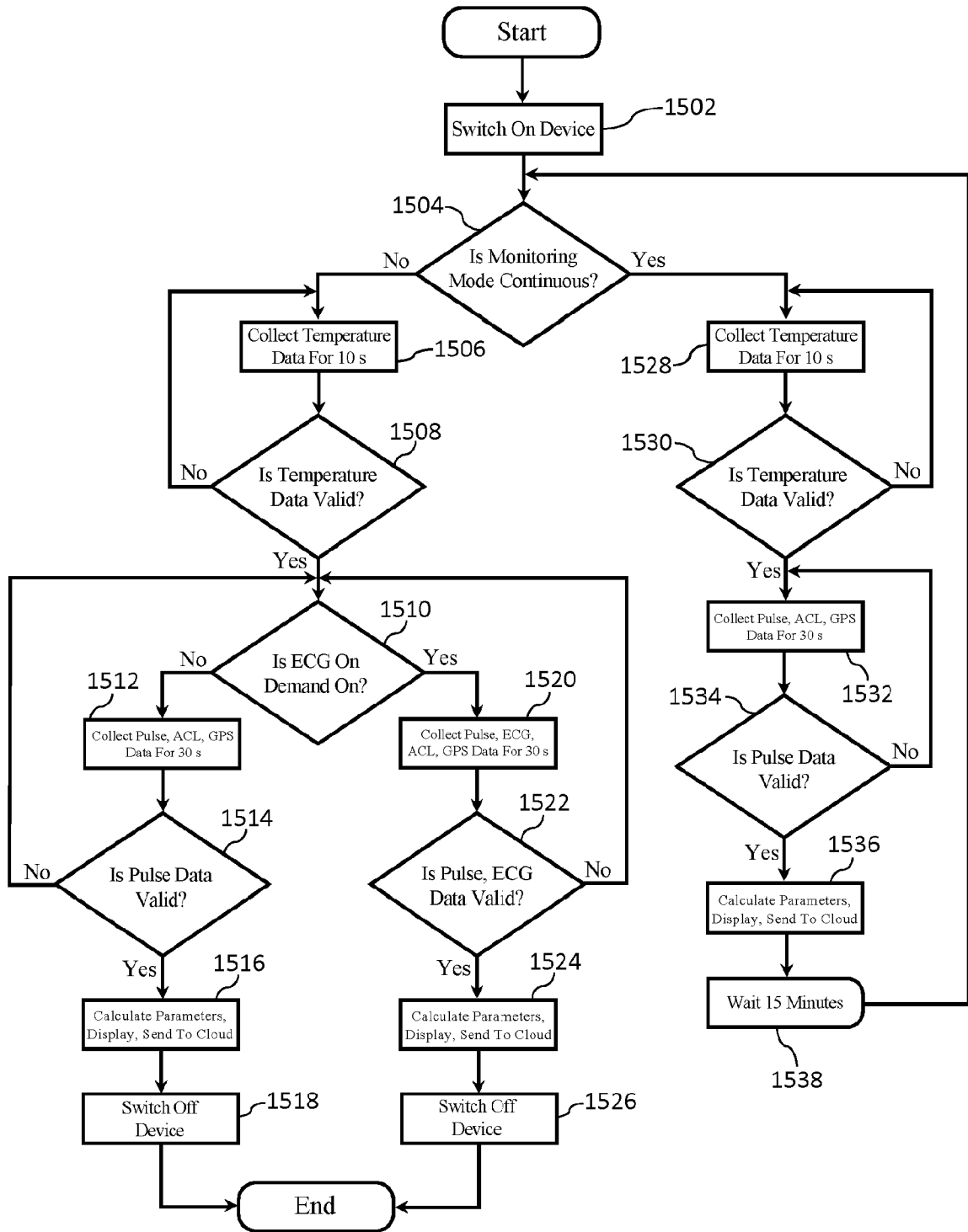

FIG. 15

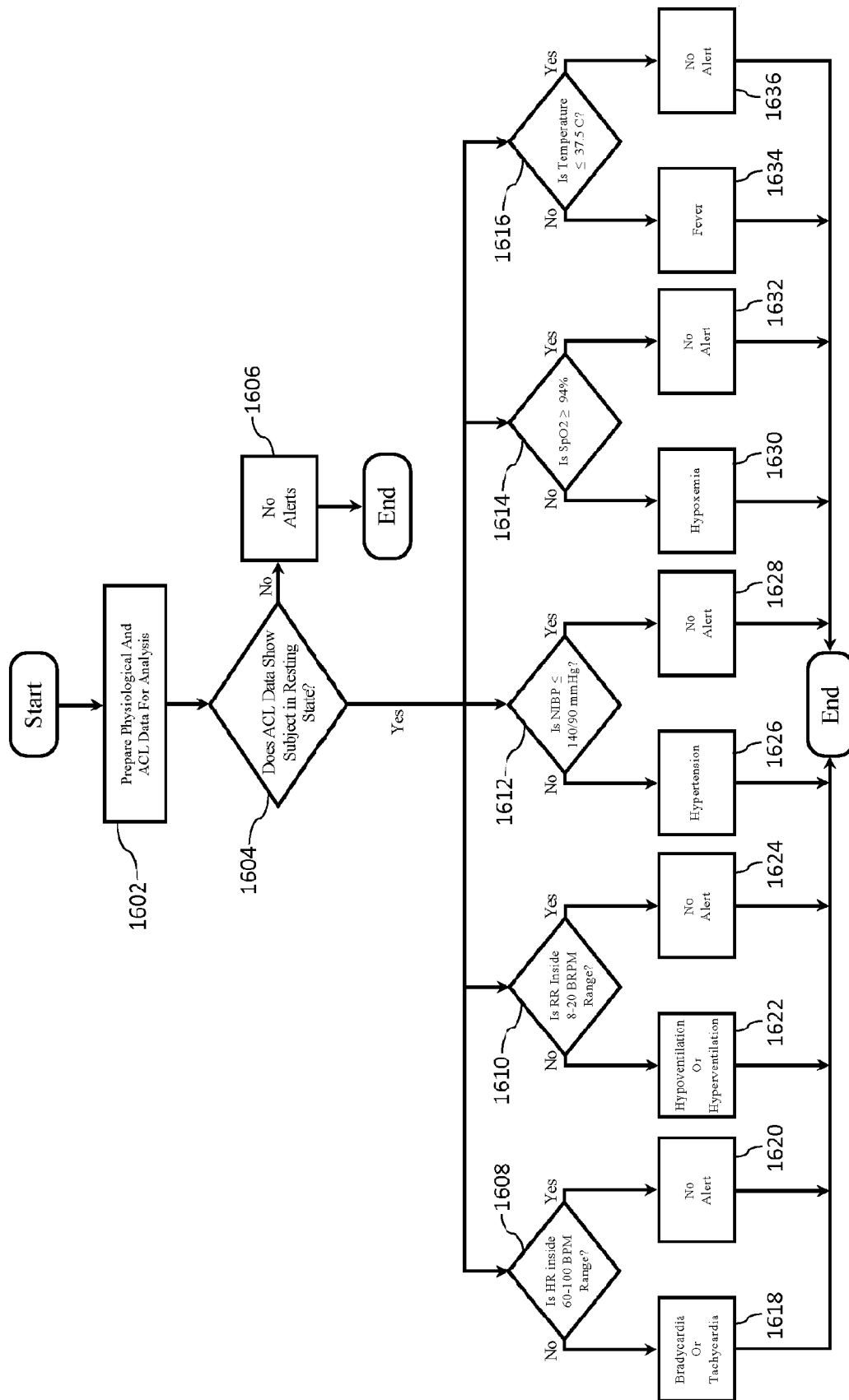

FIG. 16

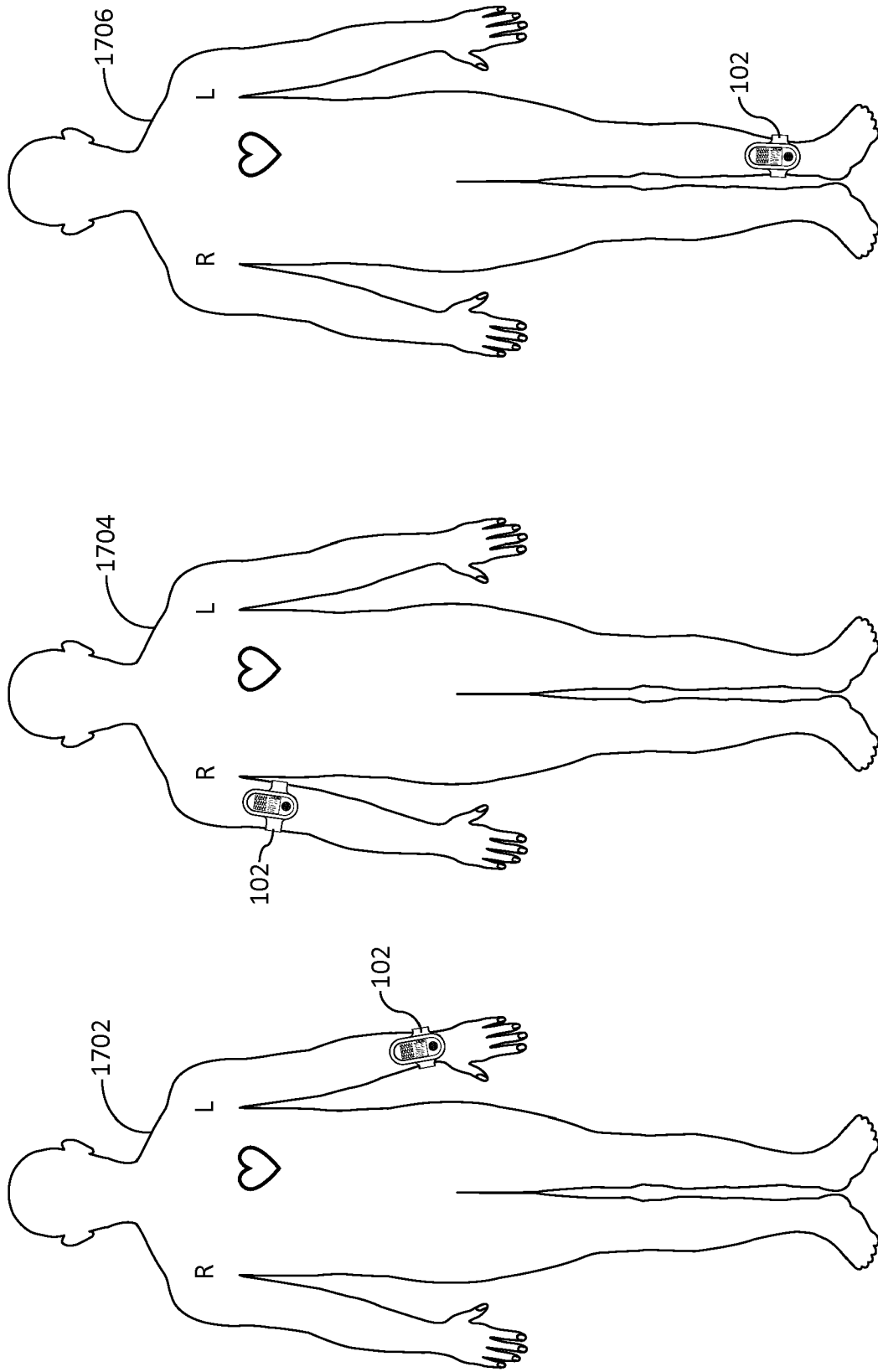

FIG. 17

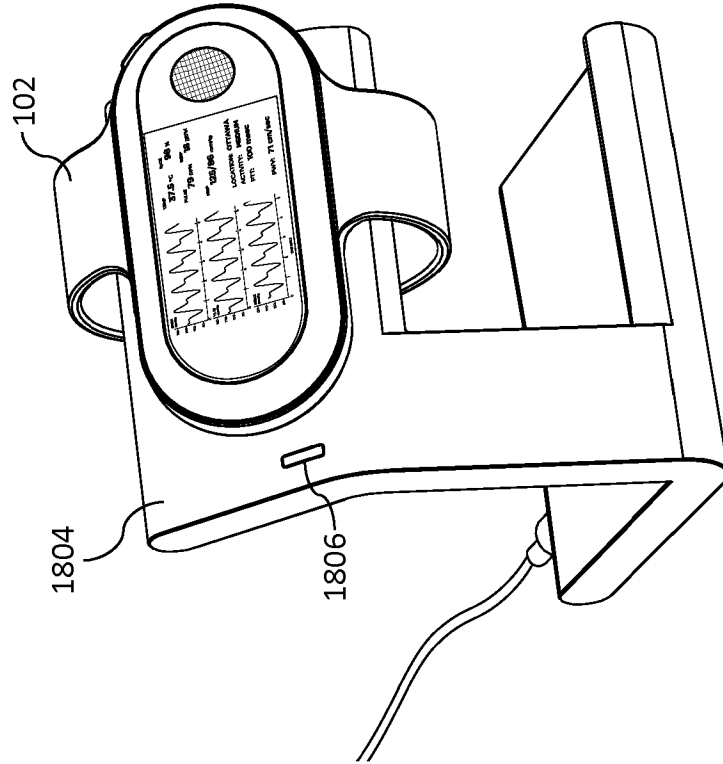

FIG. 18B

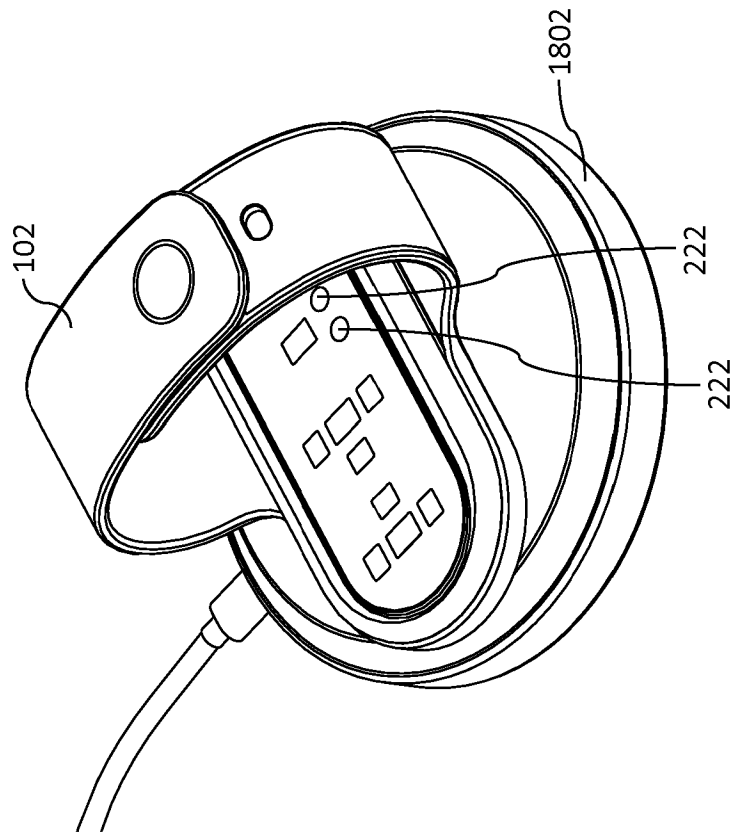

FIG. 18A

REFERENCES CITED IN THE DESCRIPTION

This list of references cited by the applicant is for the reader's convenience only. It does not form part of the European patent document. Even though great care has been taken in compiling the references, errors or omissions cannot be excluded and the EPO disclaims all liability in this regard.

Patent documents cited in the description

- US 20170238819 A1 [0005]
- US 20190059752 A1 [0005]